

### FEATURES

- SigmaDSP 28-/56-bit 50 MIPS digital audio processor**
- Fully programmable with SigmaStudio graphical tool**
- 24-bit stereo audio ADC and DAC: >98 dB SNR**
- Sampling rates from 8 kHz to 96 kHz**
- Low power: 5 mW record, 5 mW playback, 48 kHz at 1.8 V**
- 6 analog input pins, configurable for single-ended or differential inputs**
- Flexible analog input/output mixers**
- Stereo digital microphone input**
- Analog outputs: 2 differential stereo, 2 single-ended stereo, 1 mono headphone driver output**
- PLL supporting input clocks from 8 MHz to 27 MHz**
- Analog automatic level control (ALC)**
- Microphone bias reference voltage**
- Analog and digital I/O: 1.8 V to 3.65 V**
- I<sup>2</sup>C and SPI control interfaces**
- Digital audio serial data I/O: stereo and time-division multiplexing (TDM) modes**
- Software-controllable clickless mute**
- Software power-down**
- GPIO pins for digital controls and outputs**
- 32-lead, 5 mm × 5 mm LFCSP**
- 40°C to +85°C operating temperature range**

### APPLICATIONS

- Smartphones/multimedia phones**
- Digital still cameras/digital video cameras**
- Portable media players/portable audio players**
- Phone accessories products**

### GENERAL DESCRIPTION

The ADAU1761 is a low power, stereo audio codec with integrated digital audio processing that supports stereo 48 kHz record and playback at 10 mW from a 1.8 V analog supply. The stereo audio ADCs and DACs support sample rates from 8 kHz to 96 kHz as well as a digital volume control.

The SigmaDSP® core features 28-bit processing (56-bit double precision). The processor allows system designers to compensate for the real-world limitations of microphones, speakers, amplifiers, and listening environments, resulting in a dramatic improvement in the perceived audio quality through equalization, multiband compression, limiting, and third-party branded algorithms.

The SigmaStudio™ graphical development tool is used to program the ADAU1761. This software includes audio processing blocks such as filters, dynamics processors, mixers, and low level DSP functions for fast development of custom signal flows.

The record path includes an integrated microphone bias circuit and six inputs. The inputs can be mixed and muxed before the ADC, or they can be configured to bypass the ADC. The ADAU1761 includes a stereo digital microphone input.

The ADAU1761 includes five high power output drivers (two differential and three single-ended), supporting stereo headphones, an earpiece, or other output transducer. AC-coupled or capless configurations are supported. Individual fine level controls are supported on all analog outputs. The output mixer stage allows for flexible routing of audio.

### FUNCTIONAL BLOCK DIAGRAM

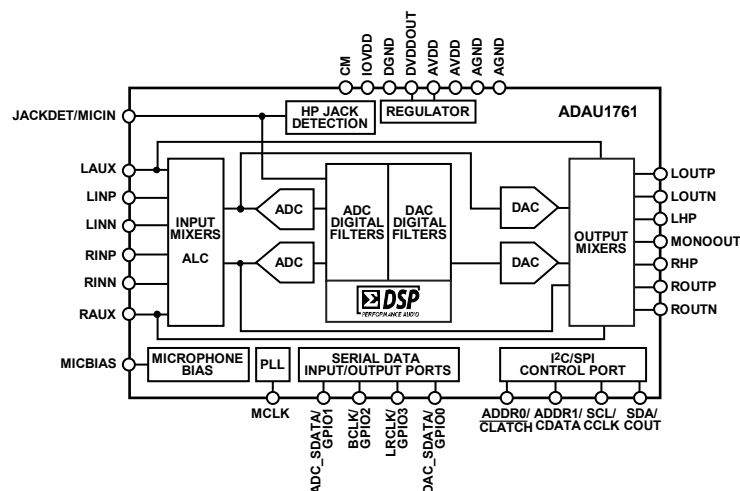

Figure 1.

Rev. 0

Information furnished by Analog Devices is believed to be accurate and reliable. However, no responsibility is assumed by Analog Devices for its use, nor for any infringements of patents or other rights of third parties that may result from its use. Specifications subject to change without notice. No license is granted by implication or otherwise under any patent or patent rights of Analog Devices. Trademarks and registered trademarks are the property of their respective owners.

## TABLE OF CONTENTS

Features .....	1	ALC Parameters.....	30
Applications.....	1	Noise Gate Function .....	31
General Description .....	1	Playback Signal Path .....	33
Functional Block Diagram .....	1	Output Signal Paths .....	33
Revision History .....	2	Headphone Output .....	33
Specifications.....	3	Line Outputs .....	35
Analog Performance Specifications .....	3	Control Ports.....	36
Power Supply Specifications.....	6	I <sup>2</sup> C Port .....	36
Typical Current Consumption.....	6	SPI Port .....	39
Typical Power Management Measurements .....	7	Serial Data Input/Output Ports .....	40
Digital Filters.....	8	Applications Information .....	42
Digital Input/Output Specifications.....	8	Power Supply Bypass Capacitors.....	42
Digital Timing Specifications .....	9	GSM Noise Filter .....	42
Digital Timing Diagrams.....	10	Grounding.....	42
Absolute Maximum Ratings.....	12	Exposed Pad PCB Design .....	42
Thermal Resistance .....	12	DSP Core .....	43
ESD Caution.....	12	Signal Processing.....	43
Pin Configuration and Function Descriptions.....	13	Architecture .....	43
Typical Performance Characteristics .....	15	Program Counter .....	43
System Block Diagrams .....	18	Features.....	43
Theory of Operation .....	21	Numeric Formats .....	44
Startup, Initialization, and Power .....	22	Programming.....	44
Power-Up Sequence .....	22	Program RAM, Parameter RAM, and Data RAM.....	45
Power Reduction Modes.....	22	Program RAM .....	45
Digital Power Supply.....	22	Parameter RAM.....	45
Input/Output Power Supply.....	22	Data RAM .....	45
Clock Generation and Management.....	22	Read/Write Data Formats .....	45
Clocking and Sampling Rates .....	24	Software Safeload .....	46
Core Clock.....	24	Software Slew .....	47
Sampling Rates.....	25	General-Purpose Input/Output.....	48
PLL .....	25	GPIO Pins Set from the Control Port.....	48
Record Signal Path.....	27	Control Registers.....	49
Input Signal Paths.....	27	Control Register Details .....	50
Analog-to-Digital Converters.....	29	Outline Dimensions .....	91
Automatic Level Control (ALC) .....	30	Ordering Guide .....	91

## REVISION HISTORY

1/09—Revision 0: Initial Version

## SPECIFICATIONS

Supply voltage (AVDD) = 3.3 V, T<sub>A</sub> = 25°C, master clock = 12.288 MHz (48 kHz f<sub>s</sub>, 256 × f<sub>s</sub> mode), input sample rate = 48 kHz, measurement bandwidth = 20 Hz to 20 kHz, word width = 24 bits, C<sub>LOAD</sub> (digital output) = 20 pF, I<sub>LOAD</sub> (digital output) = 2 mA, V<sub>IH</sub> = 2 V, V<sub>IL</sub> = 0.8 V, unless otherwise noted. Performance of all channels is identical, exclusive of the interchannel gain mismatch and interchannel phase deviation specifications.

### ANALOG PERFORMANCE SPECIFICATIONS

Specifications guaranteed at 25°C (ambient).

Table 1.

Parameter	Test Conditions/Comments	Min	Typ	Max	Unit
<b>ANALOG-TO-DIGITAL CONVERTERS</b>					
ADC Resolution	ADC performance excludes mixers and PGA All ADCs		24		Bits
Digital Attenuation Step			0.375		dB
Digital Attenuation Range			95		dB
<b>INPUT RESISTANCE</b>					
Single-Ended Line Input	–12 dB gain		83		kΩ
	0 dB gain		21		kΩ
	6 dB gain		10.5		kΩ
PGA Inverting Inputs	–12 dB gain		84.5		kΩ
	0 dB gain		53		kΩ
	35.25 dB gain		2		kΩ
PGA Noninverting Inputs	All gains		105		kΩ
<b>SINGLE-ENDED LINE INPUT</b>					
Full-Scale Input Voltage (0 dB)	Scales linearly with AVDD AVDD = 1.8 V AVDD = 3.3 V		AVDD/3.3 0.55 (1.56) 1.0 (2.83)		V rms V rms (V p-p) V rms (V p-p)
Dynamic Range	20 Hz to 20 kHz, –60 dB input				
With A-Weighted Filter (RMS)	AVDD = 1.8 V AVDD = 3.3 V		94 99		dB dB
No Filter (RMS)	AVDD = 1.8 V AVDD = 3.3 V		91 96		dB dB
Total Harmonic Distortion + Noise	–1 dBFS AVDD = 1.8 V AVDD = 3.3 V		–88 –90		dB dB
Signal-to-Noise Ratio					
With A-Weighted Filter (RMS)	AVDD = 1.8 V AVDD = 3.3 V		94 99		dB dB
No Filter (RMS)	AVDD = 1.8 V AVDD = 3.3 V		91 96		dB dB
Gain per Step			3		dB
Total Gain Range		–12		+6	dB
Mute Attenuation			–87		dB
Interchannel Gain Mismatch			0.005		dB
Offset Error			0		mV
Gain Error			–12		%
Interchannel Isolation			68		dB
Power Supply Rejection Ratio	CM capacitor = 20 μF 100 mV p-p @ 217 Hz 100 mV p-p @ 1 kHz		65 67		dB dB
<b>PSEUDO-DIFFERENTIAL PGA INPUT</b>					
Full-Scale Input Voltage (0 dB)	Scales linearly with AVDD AVDD = 1.8 V		AVDD/3.3 0.55 (1.56)		V rms V rms (V p-p)

# ADAU1761

Parameter	Test Conditions/Comments	Min	Typ	Max	Unit
Dynamic Range	AVDD = 3.3 V		1.0 (2.83)		V rms (V p-p)
	20 Hz to 20 kHz, -60 dB input				
With A-Weighted Filter (RMS)	AVDD = 1.8 V		92		dB
	AVDD = 3.3 V		98		dB
No Filter (RMS)	AVDD = 1.8 V		90		dB
	AVDD = 3.3 V		95		dB
Total Harmonic Distortion + Noise	-1 dBFS				
	AVDD = 1.8 V		-88		dB
	AVDD = 3.3 V		-89		dB
Signal-to-Noise Ratio					
	AVDD = 1.8 V		92		dB
With A-Weighted Filter (RMS)	AVDD = 3.3 V		98		dB
	AVDD = 1.8 V		90		dB
No Filter (RMS)	AVDD = 3.3 V		95		dB
	PGA gain		0.75		dB
Volume Control Step	PGA gain				dB
Volume Control Range	PGA gain	-12		+35.25	dB
PGA Boost			20		dB
Mute Attenuation			-87		dB
Interchannel Gain Mismatch			0.005		dB
Offset Error			0		mV
Gain Error			-14		%
Interchannel Isolation			83		dB
Common-Mode Rejection Ratio	100 mV rms, 1 kHz		65		dB
	100 mV rms, 20 kHz		65		dB
<b>FULL DIFFERENTIAL PGA INPUT</b>					
Full-Scale Input Voltage (0 dB)	Differential PGA inputs				
	Scales linearly with AVDD		AVDD/3.3		V rms
	AVDD = 1.8 V		0.55 (1.56)		V rms (V p-p)
	AVDD = 3.3 V		1.0 (2.83)		V rms (V p-p)
Dynamic Range	20 Hz to 20 kHz, -60 dB input				
	AVDD = 1.8 V		92		dB
With A-Weighted Filter (RMS)	AVDD = 3.3 V		98		dB
	AVDD = 1.8 V		90		dB
No Filter (RMS)	AVDD = 3.3 V		95		dB
	-1 dBFS				
Total Harmonic Distortion + Noise	AVDD = 1.8 V		-70		dB
	AVDD = 3.3 V		-78		dB
Signal-to-Noise Ratio					
	AVDD = 1.8 V		92		dB
With A-Weighted Filter (RMS)	AVDD = 3.3 V		98		dB
	AVDD = 1.8 V		90		dB
No Filter (RMS)	AVDD = 3.3 V		95		dB
	PGA gain		0.75		dB
Volume Control Step	PGA gain				dB
Volume Control Range	PGA gain	-12		+35.25	dB
PGA Boost			20		dB
Mute Attenuation			-87		dB
Interchannel Gain Mismatch			0.005		dB
Offset Error			0		mV
Gain Error			-14		%
Interchannel Isolation			83		dB
Common-Mode Rejection Ratio	100 mV rms, 1 kHz		65		dB
	100 mV rms, 20 kHz		65		dB

Parameter	Test Conditions/Comments	Min	Typ	Max	Unit
MICROPHONE BIAS	MBIEN = 1				
Bias Voltage					
0.65 × AVDD	AVDD = 1.8 V, MBI = 1		1.17		V
	AVDD = 3.3 V, MBI = 1		2.145		V
0.90 × AVDD	AVDD = 1.8 V, MBI = 0		1.62		V
	AVDD = 3.3 V, MBI = 0		2.97		V
Bias Current Source	AVDD = 3.3 V, MBI = 0, MPERF = 1			3	mA
Noise in the Signal Bandwidth	AVDD = 3.3 V, 1 kHz to 20 kHz				
	MBI = 0, MPERF = 0		42		nV/√Hz
	MBI = 0, MPERF = 1		85		nV/√Hz
	MBI = 1, MPERF = 0		25		nV/√Hz
	MBI = 1, MPERF = 1		37		nV/√Hz
DIGITAL-TO-ANALOG CONVERTERS	DAC performance excludes mixers and headphone amplifier				
DAC Resolution	All DACs		24		Bits
Digital Attenuation Step			0.375		dB
Digital Attenuation Range			95		dB
DAC TO LINE OUTPUT					
Full-Scale Output Voltage (0 dB)	Scales linearly with AVDD		AVDD/3.3		V rms
	AVDD = 1.8 V		0.55 (1.56)		V rms (V p-p)
	AVDD = 3.3 V		1.0 (2.83)		V rms (V p-p)
Analog Volume Control Step	Line output volume control		0.75		dB
Analog Volume Control Range	Line output volume control	-57	1	+6	dB
Mute Attenuation			-87		dB
Dynamic Range	20 Hz to 20 kHz, -60 dB input				
With A-Weighted Filter (RMS)	AVDD = 1.8 V		96		dB
	AVDD = 3.3 V		101		dB
No Filter (RMS)	AVDD = 1.8 V		93.5		dB
	AVDD = 3.3 V		98		dB
Total Harmonic Distortion + Noise	-1 dBFS				dB
	AVDD = 1.8 V		-90		dB
	AVDD = 3.3 V		-92		dB
Signal-to-Noise Ratio					
With A-Weighted Filter (RMS)	AVDD = 1.8 V		96		dB
	AVDD = 3.3 V		101		dB
No Filter (RMS)	AVDD = 1.8 V		93.5		dB
	AVDD = 3.3 V		98		dB
Power Supply Rejection Ratio	CM capacitor = 20 μF				
	100 mV p-p @ 217 Hz		56		dB
	100 mV p-p @ 1 kHz		70		dB
Gain Error			3		%
Interchannel Gain Mismatch			0.005		dB
Offset Error			0		mV
Interchannel Isolation	1 kHz, 0 dBFS input signal		100		dB
DAC TO CAPLESS HEADPHONE OUTPUT	P <sub>o</sub> = output power per channel				
Total Harmonic Distortion + Noise	-4 dBFS				
16 Ω load	AVDD = 1.8 V, P <sub>o</sub> = 6.4 mW		-76		dB
	AVDD = 3.3 V, P <sub>o</sub> = 21.1 mW		-82		dB
32 Ω load	AVDD = 1.8 V, P <sub>o</sub> = 3.8 mW		-82		dB
	AVDD = 3.3 V, P <sub>o</sub> = 10.6 mW		-82		dB
Power Supply Rejection Ratio	CM capacitor = 20 μF				
	100 mV p-p @ 217 Hz		56		dB
	100 mV p-p @ 1 kHz		67		dB

# ADAU1761

Parameter	Test Conditions/Comments	Min	Typ	Max	Unit
Interchannel Isolation	1 kHz, 0 dBFS input signal		73		dB
REFERENCE					
Common-Mode Reference Output	CM pin		AVDD/2		V

## POWER SUPPLY SPECIFICATIONS

Table 2.

Parameter	Test Conditions/Comments	Min	Typ	Max	Unit	
<b>SUPPLIES</b>						
Voltage	DVDDOUT		1.56		V	
	AVDD	1.8	3.3	3.65	V	
	IOVDD	1.63	3.3	3.65	V	
Digital I/O Current (IOVDD = 1.8 V) Slave Mode	20 pF capacitive load on all digital pins $f_s = 48$ kHz		0.25		mA	
			0.48		mA	
			0.07		mA	
	Master Mode	20 pF capacitive load on all digital pins $f_s = 48$ kHz		0.62		mA
				1.23		mA
				0.11		mA
Digital I/O Current (IOVDD = 3.3 V) Slave Mode	20 pF capacitive load on all digital pins $f_s = 48$ kHz		0.48		mA	
			0.9		mA	
			0.13		mA	
	Master Mode	20 pF capacitive load on all digital pins $f_s = 48$ kHz		1.51		mA
				3		mA
				0.27		mA
Analog Current (AVDD)	See Table 3					

## TYPICAL CURRENT CONSUMPTION

Master clock = 12.288 MHz, input sample rate = 48 kHz, input tone = 1 kHz, normal power management settings, ADC input @ -1 dBFS, DAC input @ 0 dBFS. For total power consumption, add the IOVDD current listed in Table 2.

Table 3.

Operating Voltage	Audio Path	Clock Generation	Typical AVDD Current Consumption (mA)
AVDD = IOVDD = 3.3 V	Record stereo differential to ADC	Direct MCLK	5.24
		Integer PLL	6.57
	DAC stereo playback to line output (10 k $\Omega$ )	Direct MCLK	5.55
		Integer PLL	6.90
	DAC stereo playback to headphone (16 $\Omega$ )	Direct MCLK	55.5
		Integer PLL	56.8
	DAC stereo playback to headphone (32 $\Omega$ )	Direct MCLK	30.9
Integer PLL		32.25	
DAC stereo playback to capless headphone (32 $\Omega$ )	Direct MCLK	56.75	
	Integer PLL	58	
Record aux stereo bypass to line output (10 k $\Omega$ )	Direct MCLK	1.9	
	Integer PLL	3.3	
AVDD = IOVDD = 1.8 V	Record stereo differential to ADC	Direct MCLK	4.25
		Integer PLL	5.55
	DAC stereo playback to line output (10 k $\Omega$ )	Direct MCLK	4.7
	Integer PLL	5.7	

Operating Voltage	Audio Path	Clock Generation	Typical AVDD Current Consumption (mA)
AVDD = IOVDD = 1.8 V	DAC stereo playback to headphone (16 Ω)	Direct MCLK Integer PLL	30.81 32
	DAC stereo playback to headphone (32 Ω)	Direct MCLK Integer PLL	18.3 19.5
	DAC stereo playback to capless headphone (32 Ω)	Direct MCLK Integer PLL	32.6 33.7
	Record aux stereo bypass to line output (10 kΩ)	Direct MCLK Integer PLL	1.9 3.07

### TYPICAL POWER MANAGEMENT MEASUREMENTS

Master clock = 12.288 MHz, integer PLL, input sample rate = 48 kHz, input tone = 1 kHz. Pseudo-differential input to ADCs, DACs to line output with 10 kΩ load. ADC input @ -1 dBFS, DAC input @ 0 dBFS. In Table 4, the mixer boost and power management conditions are set for MXBIAS[1:0], ADCBIAS[1:0], HPBIAS[1:0], and DACBIAS[1:0]. RBIAS[1:0] and PBIAS[1:0] do not have an extreme power saving mode and are therefore set for power saving mode in the extreme power saving rows in Table 4.

Table 4.

Operating Voltage	Power Management Setting	Mixer Boost Setting	Typical AVDD Current Consumption (mA)	Typical ADC THD + N (dB)	Typical Line Output THD + N (dB)
AVDD = IOVDD = 3.3 V	Normal (default)	Normal operation	9.6	-91	-92.5
		Boost Level 1	9.75	-91.5	-92.5
		Boost Level 2	9.92	-91.5	-92.5
		Boost Level 3	10.25	-91.5	-92.5
	Extreme power saving	Normal operation	7.09	-84.5	-87
		Boost Level 1	7.19	-84.8	-87.1
		Boost Level 2	7.29	-84.8	-87.1
		Boost Level 3	7.49	-85	-87.1
	Power saving	Normal operation	7.67	-89.5	-90
		Boost Level 1	7.77	-89.5	-90
		Boost Level 2	7.86	-89.8	-90
		Boost Level 3	8.07	-89.8	-90
	Enhanced performance	Normal operation	10.55	-91	-93.5
		Boost Level 1	10.74	-91	-93.5
		Boost Level 2	10.93	-91	-93.5
		Boost Level 3	11.33	-91	-93.5
AVDD = IOVDD = 1.8 V	Normal (default)	Normal operation	8.1	-88	-91.2
		Boost Level 1	8.26	-88	-91.2
		Boost Level 2	8.41	-88	-91.2
		Boost Level 3	8.73	-88	-91.2
	Extreme power saving	Normal operation	5.73	-85	-86
		Boost Level 1	5.82	-85.4	-86
		Boost Level 2	5.91	-85.5	-86
		Boost Level 3	6.1	-85.5	-86
	Power saving	Normal operation	6.27	-86	-89.4
		Boost Level 1	6.36	-86.1	-89.5
		Boost Level 2	6.46	-86.3	-89.5
		Boost Level 3	6.65	-86.3	-89.5
	Enhanced performance	Normal operation	9.01	-88	-91.5
		Boost Level 1	9.2	-88	-91.5
		Boost Level 2	9.38	-88	-91.5
		Boost Level 3	9.76	-88	-91.5

# ADAU1761

## DIGITAL FILTERS

Table 5.

Parameter	Mode	Factor	Min	Typ	Max	Unit
ADC DECIMATION FILTER	All modes, typ @ 48 kHz					
Pass Band		$0.4375 f_s$		21		kHz
Pass-Band Ripple				$\pm 0.015$		dB
Transition Band		$0.5 f_s$		24		kHz
Stop Band		$0.5625 f_s$		27		kHz
Stop-Band Attenuation				67		dB
Group Delay		$22.9844/f_s$		479		$\mu s$
DAC INTERPOLATION FILTER						
Pass Band	48 kHz mode, typ @ 48 kHz	$0.4535 f_s$		22		kHz
	96 kHz mode, typ @ 96 kHz	$0.3646 f_s$		69		kHz
Pass-Band Ripple	48 kHz mode, typ @ 48 kHz				$\pm 0.01$	dB
	96 kHz mode, typ @ 96 kHz				$\pm 0.05$	dB
Transition Band	48 kHz mode, typ @ 48 kHz	$0.5 f_s$		24		kHz
	96 kHz mode, typ @ 96 kHz	$0.5 f_s$		48		kHz
Stop Band	48 kHz mode, typ @ 48 kHz	$0.5465 f_s$		26		kHz
	96 kHz mode, typ @ 96 kHz	$0.6354 f_s$		61		kHz
Stop-Band Attenuation	48 kHz mode, typ @ 48 kHz			69		dB
	96 kHz mode, typ @ 96 kHz			68		dB
Group Delay	48 kHz mode, typ @ 48 kHz	$25/f_s$		521		$\mu s$
	96 kHz mode, typ @ 96 kHz	$11/f_s$		115		$\mu s$

## DIGITAL INPUT/OUTPUT SPECIFICATIONS

$-40^{\circ}C < T_A < +85^{\circ}C$ , IOVDD = 3.3 V  $\pm$  10%.

Table 6.

Parameter	Test Conditions/Comments	Min	Typ	Max	Unit
Input Voltage High ( $V_{IH}$ )		$0.7 \times IOVDD$			V
Input Voltage Low ( $V_{IL}$ )				$0.3 \times IOVDD$	V
Input Leakage (Pull-Ups/Pull-Downs Disabled)	$I_{IH} @ V_{IH} = 3.3 V$	-0.17		+0.17	$\mu A$
	$I_{IL} @ V_{IL} = 0 V$	-0.17		+0.17	$\mu A$
	$I_{IL} @ V_{IL} = 0 V$ (MCLK pin)	-13.5		-0.5	$\mu A$
Input Leakage (Pull-Ups Enabled)	$I_{IH} @ V_{IH} = 3.3 V$	-0.7		+0.7	$\mu A$
	$I_{IL} @ V_{IL} = 0 V$	-13.5		-0.5	$\mu A$
Input Leakage (Pull-Downs Enabled)	$I_{IH} @ V_{IH} = 3.3 V$	2.7		8.3	$\mu A$
	$I_{IL} @ V_{IL} = 0 V$	-0.18		+0.18	$\mu A$
Output Voltage High ( $V_{OH}$ )	$I_{OH} = 2 mA @ 3.3 V, 0.85 mA @ 1.8 V$	$0.8 \times IOVDD$			V
Output Voltage Low ( $V_{OL}$ )	$I_{OL} = 2 mA @ 3.3 V, 0.85 mA @ 1.8 V$			$0.1 \times IOVDD$	V
Input Capacitance				5	pF



**DIGITAL TIMING SPECIFICATIONS**-40°C < T<sub>A</sub> < +85°C, IOVDD = 3.3 V ± 10%.**Table 7. Digital Timing**

Parameter	Limit		Unit	Description
	t <sub>MIN</sub>	t <sub>MAX</sub>		
<b>MASTER CLOCK</b>				
t <sub>MP</sub>	74	488	ns	MCLK period, 256 × f <sub>s</sub> mode.
t <sub>MP</sub>	37	244	ns	MCLK period, 512 × f <sub>s</sub> mode.
t <sub>MP</sub>	24.7	162.7	ns	MCLK period, 768 × f <sub>s</sub> mode.
t <sub>MP</sub>	18.5	122	ns	MCLK period, 1024 × f <sub>s</sub> mode.
<b>SERIAL PORT</b>				
t <sub>BIL</sub>	5		ns	BCLK pulse width low.
t <sub>BIH</sub>	5		ns	BCLK pulse width high.
t <sub>LIS</sub>	5		ns	LRCLK setup. Time to BCLK rising.
t <sub>LIH</sub>	5		ns	LRCLK hold. Time from BCLK rising.
t <sub>SIS</sub>	5		ns	DAC_SDATA setup. Time to BCLK rising.
t <sub>SIH</sub>	5		ns	DAC_SDATA hold. Time from BCLK rising.
t <sub>SODM</sub>		50	ns	ADC_SDATA delay. Time from BCLK falling in master mode.
<b>SPI PORT</b>				
f <sub>CCLK</sub>		10	MHz	CCLK frequency.
t <sub>CCPL</sub>	10		ns	CCLK pulse width low.
t <sub>CCPH</sub>	10		ns	CCLK pulse width high.
t <sub>CLS</sub>	5		ns	$\overline{\text{CLATCH}}$ setup. Time to CCLK rising.
t <sub>CLH</sub>	10		ns	$\overline{\text{CLATCH}}$ hold. Time from CCLK rising.
t <sub>CLPH</sub>	10		ns	$\overline{\text{CLATCH}}$ pulse width high.
t <sub>CDS</sub>	5		ns	CDATA setup. Time to CCLK rising.
t <sub>CDH</sub>	5		ns	CDATA hold. Time from CCLK rising.
t <sub>COD</sub>		50	ns	COU <sub>T</sub> three-stated. Time from $\overline{\text{CLATCH}}$ rising.
<b>I<sup>2</sup>C PORT</b>				
f <sub>SCL</sub>		400	kHz	SCL frequency.
t <sub>SCLH</sub>	0.6		μs	SCL high.
t <sub>SCLL</sub>	1.3		μs	SCL low.
t <sub>SCS</sub>	0.6		μs	Setup time; relevant for repeated start condition.
t <sub>SCH</sub>	0.6		μs	Hold time. After this period, the first clock is generated.
t <sub>DS</sub>	100		ns	Data setup time.
t <sub>SCR</sub>		300	ns	SCL rise time.
t <sub>SCF</sub>		300	ns	SCL fall time.
t <sub>SDR</sub>		300	ns	SDA rise time.
t <sub>SDF</sub>		300	ns	SDA fall time.
t <sub>BFT</sub>	0.6		μs	Bus-free time. Time between stop and start.
<b>DIGITAL MICROPHONE</b>				R <sub>L</sub> = 1 MΩ, C <sub>L</sub> = 14 pF.
t <sub>DCF</sub>		10	ns	Digital microphone clock fall time.
t <sub>DCR</sub>		10	ns	Digital microphone clock rise time.
t <sub>DDV</sub>	22	30	ns	Digital microphone delay time for valid data.
t <sub>DDH</sub>	0	12	ns	Digital microphone delay time for data three-stated.

## DIGITAL TIMING DIAGRAMS

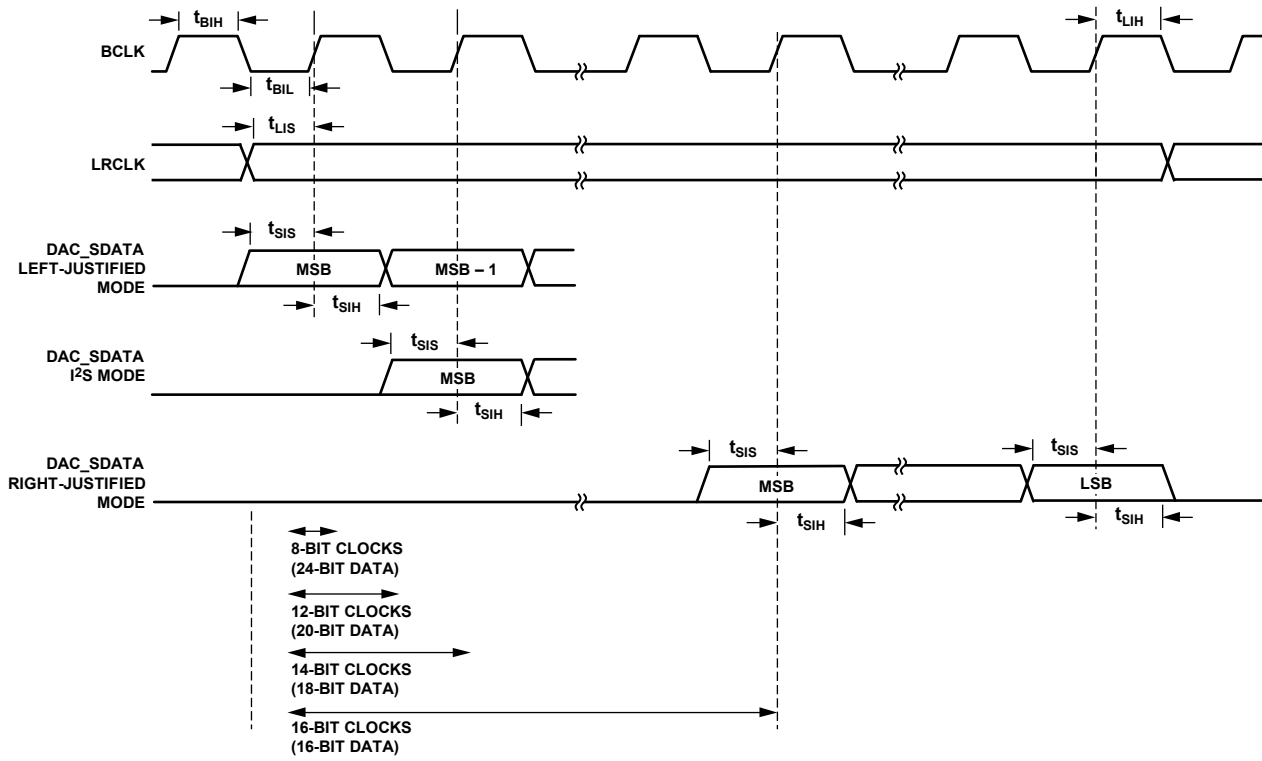

0786C-002

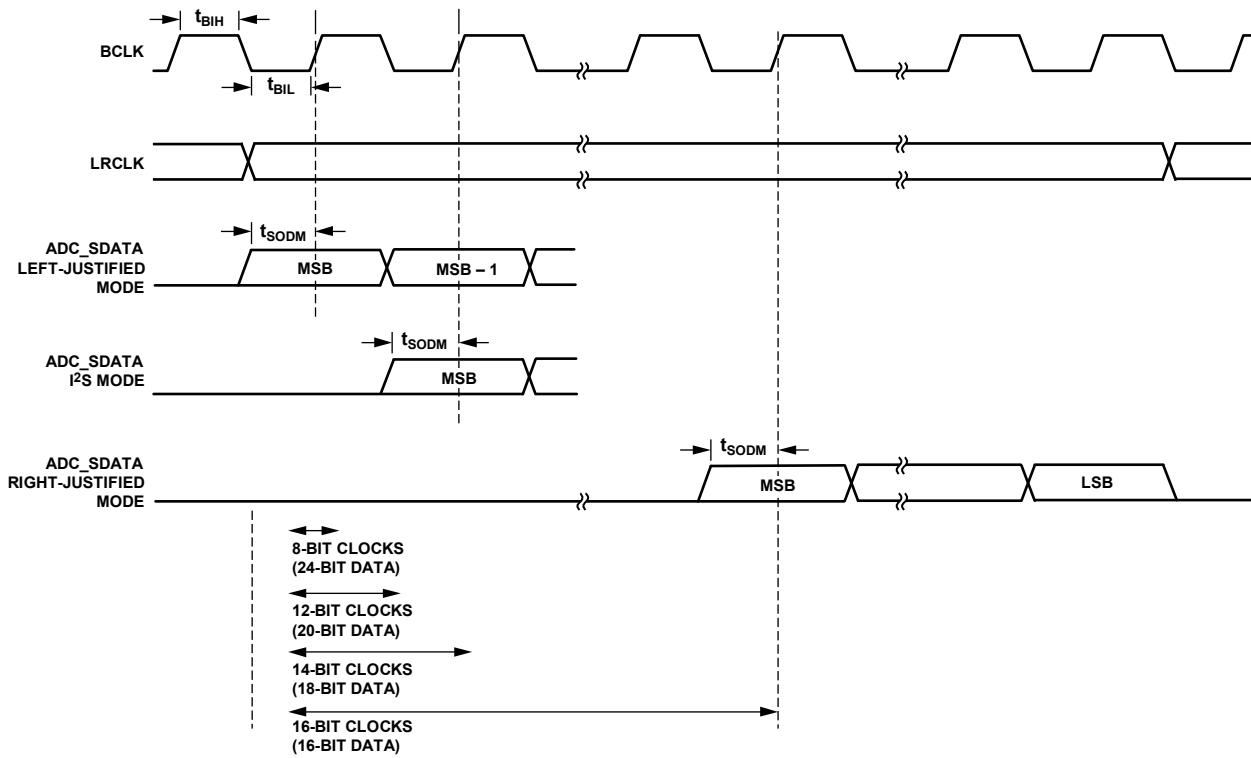

0786C-003

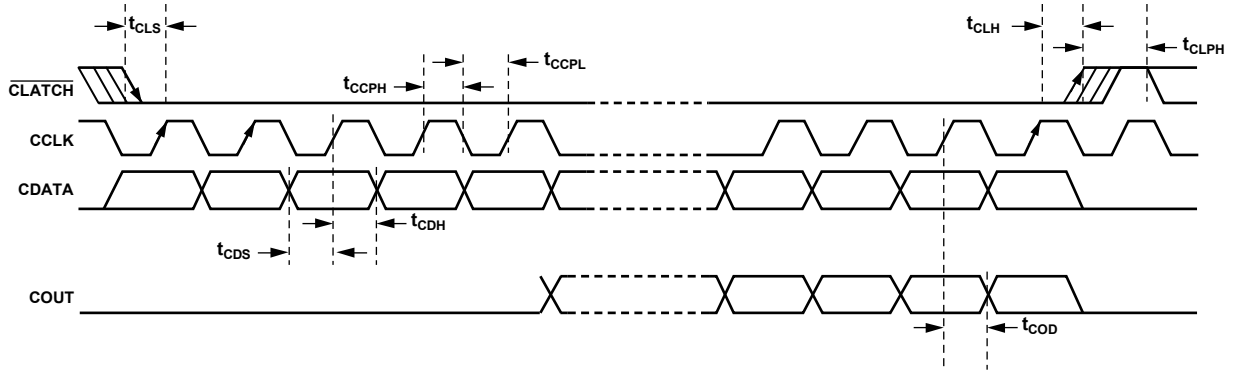

Figure 4. SPI Port Timing

07680-004

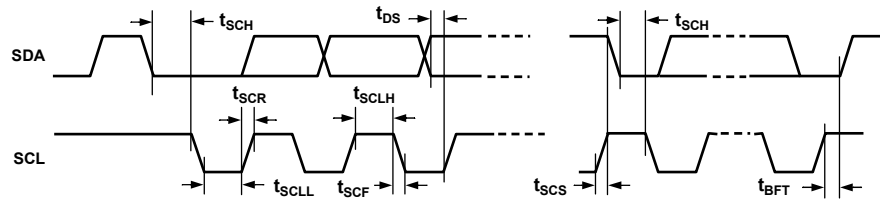

Figure 5. I<sup>2</sup>C Port Timing

07680-005

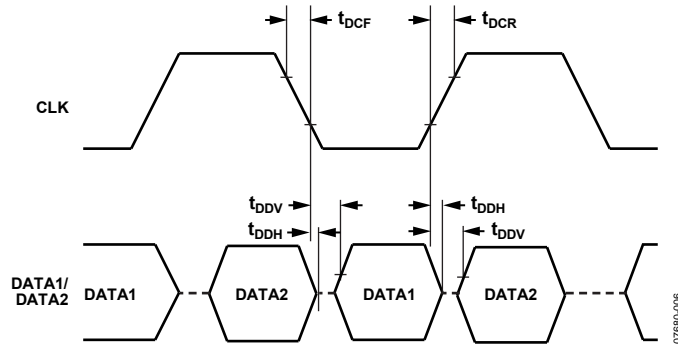

Figure 6. Digital Microphone Timing

07680-006

## ABSOLUTE MAXIMUM RATINGS

Table 8.

Parameter	Rating
Power Supply (AVDD)	-0.3 V to +3.65 V
Input Current (Except Supply Pins)	±20 mA
Analog Input Voltage (Signal Pins)	-0.3 V to AVDD + 0.3 V
Digital Input Voltage (Signal Pins)	-0.3 V to IOVDD + 0.3 V
Operating Temperature Range	-40°C to +85°C
Storage Temperature Range	-65°C to +150°C

Stresses above those listed under Absolute Maximum Ratings may cause permanent damage to the device. This is a stress rating only; functional operation of the device at these or any other conditions above those indicated in the operational section of this specification is not implied. Exposure to absolute maximum rating conditions for extended periods may affect device reliability.

## THERMAL RESISTANCE

$\theta_{JA}$  represents thermal resistance, junction-to-ambient;  $\theta_{JC}$  represents thermal resistance, junction-to-case. All characteristics are for a 4-layer board.

Table 9. Thermal Resistance

Package Type	$\theta_{JA}$	$\theta_{JC}$	Unit
32-Lead LFCSP	50.1	17	°C/W

## ESD CAUTION



**ESD (electrostatic discharge) sensitive device.** Charged devices and circuit boards can discharge without detection. Although this product features patented or proprietary protection circuitry, damage may occur on devices subjected to high energy ESD. Therefore, proper ESD precautions should be taken to avoid performance degradation or loss of functionality.

## PIN CONFIGURATION AND FUNCTION DESCRIPTIONS

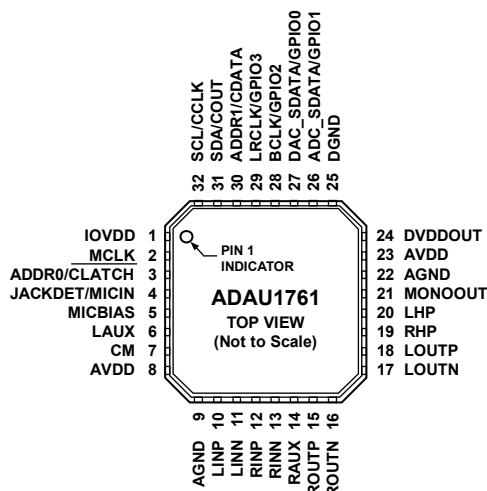

**NOTES**  
 1. THE EXPOSED PAD IS CONNECTED INTERNALLY TO THE ADAU1761 GROUNDS. FOR INCREASED RELIABILITY OF THE SOLDER JOINTS AND MAXIMUM THERMAL CAPABILITY, IT IS RECOMMENDED THAT THE PAD BE SOLDERED TO THE GROUND PLANE.

07980-007

Figure 7. Pin Configuration

Table 10. Pin Function Descriptions

Pin No.	Mnemonic	Type <sup>1</sup>	Description
1	IOVDD	PWR	Supply for Digital Input and Output Pins. The digital output pins are supplied from IOVDD, which also sets the highest input voltage that should be seen on the digital input pins. IOVDD should be set between 1.8 V and 3.3 V. The current draw of this pin is variable because it is dependent on the loads of the digital outputs. IOVDD should be decoupled to DGND with a 100 nF capacitor and a 10 μF capacitor.
2	MCLK	D_IN	External Master Clock Input.
3	ADDR0/CLATCH	D_IN	ADDR0: I <sup>2</sup> C Address Bit 0. CLATCH: SPI Latch Signal. Must go low at the beginning of an SPI transaction and high at the end of a transaction. Each SPI transaction can take a different number of CCLKs to complete, depending on the address and read/write bit that are sent at the beginning of the SPI transaction.
4	JACKDET/MICIN	D_IN	JACKDET: Detect insertion/removal of headphone plug. MICIN: Digital microphone stereo input.
5	MICBIAS	A_OUT	Bias Voltage for Electret Microphone.
6	LAUX	A_IN	Left Channel Single-Ended Auxiliary Input.
7	CM	A_OUT	AVDD/2 V Common-Mode Reference. A 10 μF to 47 μF standard decoupling capacitor should be connected between this pin and AGND to reduce crosstalk between the ADCs and DACs. This pin can be used to bias external analog circuits, as long as they are not drawing current from CM (for example, the noninverting input of an op amp).
8	AVDD	PWR	1.8 V to 3.65 V Analog Supply for DAC and Microphone Bias. This pin should be decoupled to AGND with a 100 nF capacitor.
9	AGND	PWR	Analog Ground. The AGND and DGND pins can be tied together on a common ground plane. AGND should be decoupled locally to AVDD with a 100 nF capacitor.
10	LINP	A_IN	Left Channel Noninverting Input or Single-Ended Input 0.
11	LINN	A_IN	Left Channel Inverting Input or Single-Ended Input 1.
12	RINP	A_IN	Right Channel Noninverting Input or Single-Ended Input 2.
13	RINN	A_IN	Right Channel Inverting Input or Single-Ended Input 3.
14	RAUX	A_IN	Right Channel Single-Ended Auxiliary Input.
15	ROUTP	A_OUT	Right Line Output, Positive.
16	ROUTN	A_OUT	Right Line Output, Negative.
17	LOUTN	A_OUT	Left Line Output, Negative.
18	LOUTP	A_OUT	Left Line Output, Positive.

# ADAU1761

Pin No.	Mnemonic	Type <sup>1</sup>	Description
19	RHP	A_OUT	Right Headphone Output.
20	LHP	A_OUT	Left Headphone Output.
21	MONOOUT	A_OUT	Mono Output or Virtual Ground for Capless Headphone.
22	AGND	PWR	Analog Ground. The AGND and DGND pins can be tied together on a common ground plane. AGND should be decoupled to AVDD with a 100 nF capacitor.
23	AVDD	PWR	1.8 V to 3.3 V Analog Supply for ADC, Output Driver, and Input to Digital Supply Regulator. This pin should be decoupled locally to AGND with a 100 nF capacitor.
24	DVDDOUT	PWR	Digital Core Supply Decoupling Point. The digital supply is generated from an on-board regulator and does not require an external supply. DVDDOUT should be decoupled to DGND with a 100 nF capacitor and a 10 $\mu$ F capacitor.
25	DGND	PWR	Digital Ground. The AGND and DGND pins can be tied together on a common ground plane. DGND should be decoupled to DVDDOUT and to IOVDD with 100 nF capacitors and 10 $\mu$ F capacitors.
26	ADC_SDATA/GPIO1	D_IO	ADC_SDATA: ADC Serial Output Data. GPIO1: General-Purpose Input/Output 1.
27	DAC_SDATA/GPIO0	D_IO	DAC_SDATA: DAC Serial Input Data. GPIO0: General-Purpose Input/Output 0.
28	BCLK/GPIO2	D_IO	BCLK: Serial Data Port Bit Clock. GPIO2: General-Purpose Input/Output 2.
29	LRCLK/GPIO3	D_IO	LRCLK: Serial Data Port Frame Clock. GPIO3: General-Purpose Input/Output 3.
30	ADDR1/CDATA	D_IN	ADDR1: I <sup>2</sup> C Address Bit 1. CDATA: SPI Data Input.
31	SDA/COUT	D_IO	SDA: I <sup>2</sup> C Data. This pin is a bidirectional open-collector input/output. The line connected to this pin should have a 2 k $\Omega$ pull-up resistor. COUT: This SPI data output is used for reading back registers and memory locations. It is three-state when an SPI read is not active.
32	SCL/CCLK	D_IN	SCL: I <sup>2</sup> C Clock. This pin is always an open-collector input when in I <sup>2</sup> C control mode. The line connected to this pin should have a 2 k $\Omega$ pull-up resistor. CCLK: SPI Clock. This pin can run continuously or be gated off between SPI transactions.
EP	Exposed Pad		Exposed Pad. The exposed pad is connected internally to the ADAU1761 grounds. For increased reliability of the solder joints and maximum thermal capability, it is recommended that the pad be soldered to the ground plane. See the Exposed Pad PCB Design section for more information.

<sup>1</sup> A\_IN = analog input, A\_OUT = analog output, D\_IN = digital input, D\_IO = digital input/output, PWR = power.

# TYPICAL PERFORMANCE CHARACTERISTICS

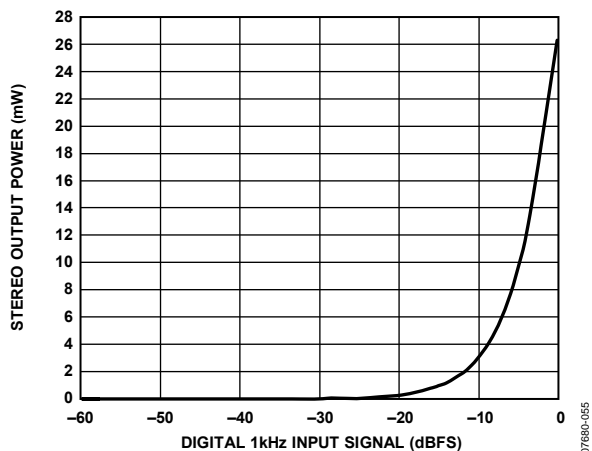

Figure 8. Headphone Amplifier Power vs. Input Level, 16 Ω Load

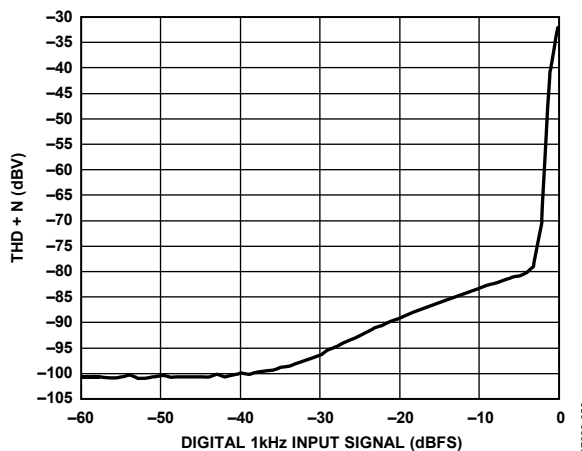

Figure 11. Headphone Amplifier THD + N vs. Input Level, 16 Ω Load

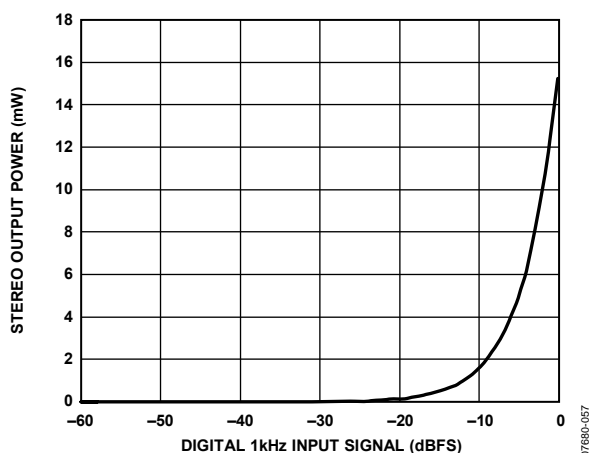

Figure 9. Headphone Amplifier Power vs. Input Level, 32 Ω Load

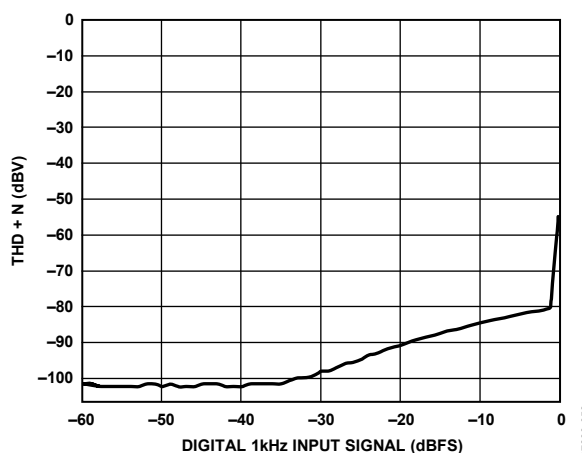

Figure 12. Headphone Amplifier THD + N vs. Input Level, 32 Ω Load

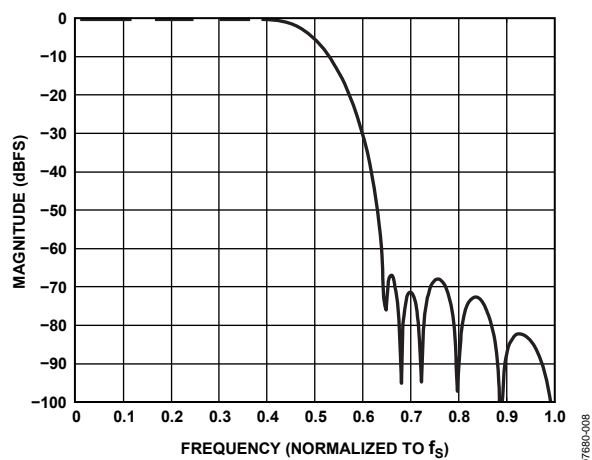

Figure 10. ADC Decimation Filter, 64× Oversampling, Normalized to  $f_s$

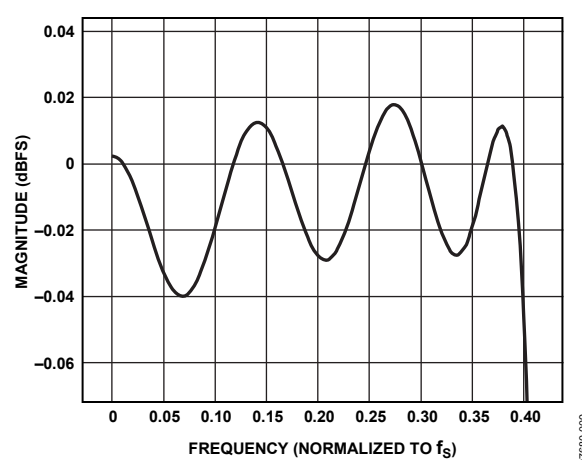

Figure 13. ADC Decimation Filter Pass-Band Ripple, 64× Oversampling, Normalized to  $f_s$

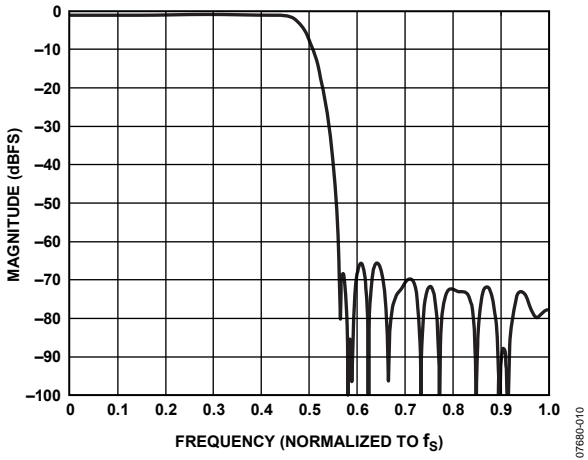

Figure 14. ADC Decimation Filter, 128x Oversampling, Normalized to  $f_s$

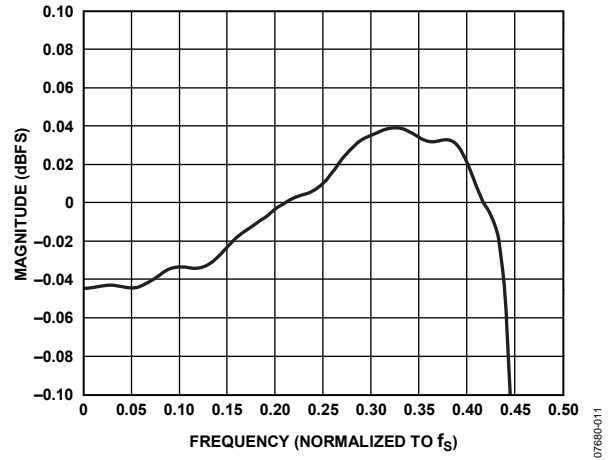

Figure 17. ADC Decimation Filter Pass-Band Ripple, 128x Oversampling, Normalized to  $f_s$

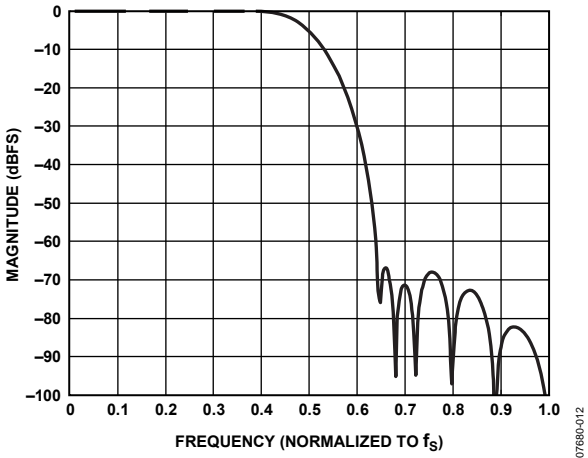

Figure 15. ADC Decimation Filter, Double-Rate Mode, Normalized to  $f_s$

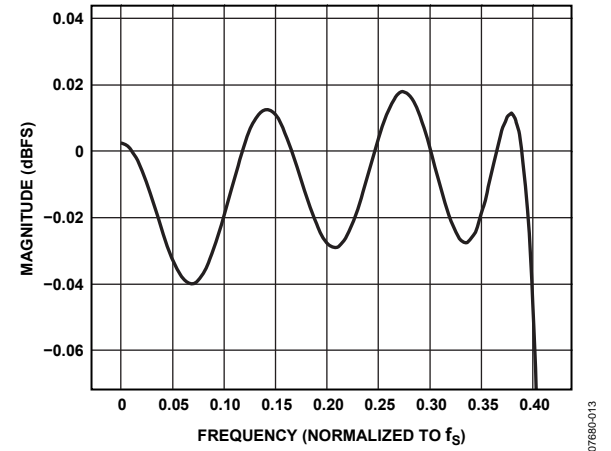

Figure 18. ADC Decimation Filter Pass-Band Ripple, Double-Rate Mode, Normalized to  $f_s$

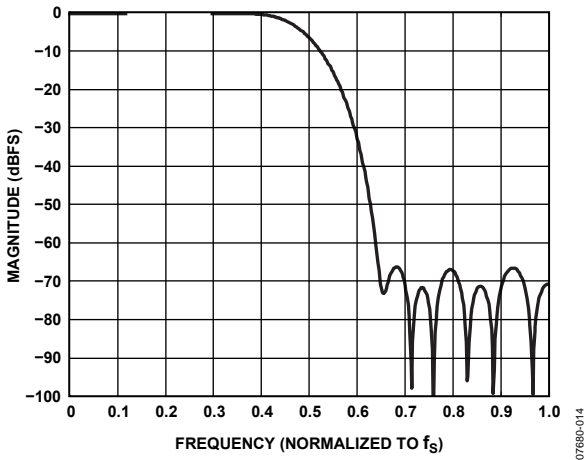

Figure 16. DAC Interpolation Filter, 64x Oversampling, Normalized to  $f_s$

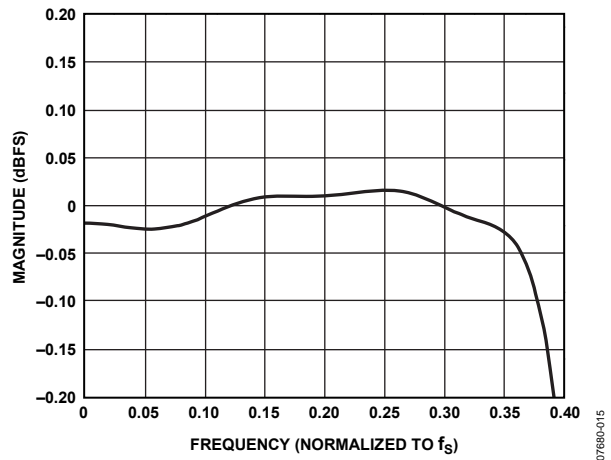

Figure 19. DAC Interpolation Filter Pass-Band Ripple, 64x Oversampling, Normalized to  $f_s$



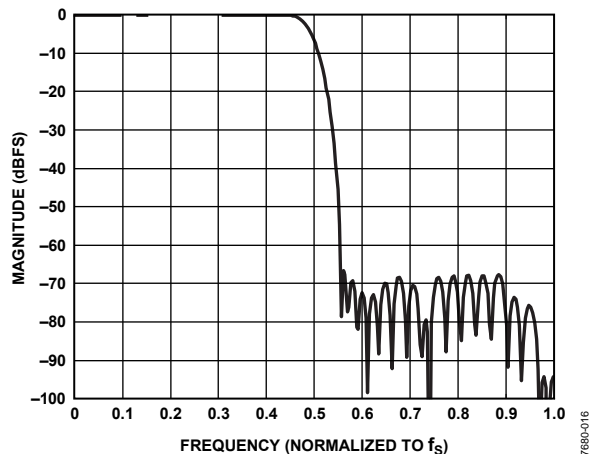

Figure 20. DAC Interpolation Filter, 128x Oversampling, Normalized to  $f_s$

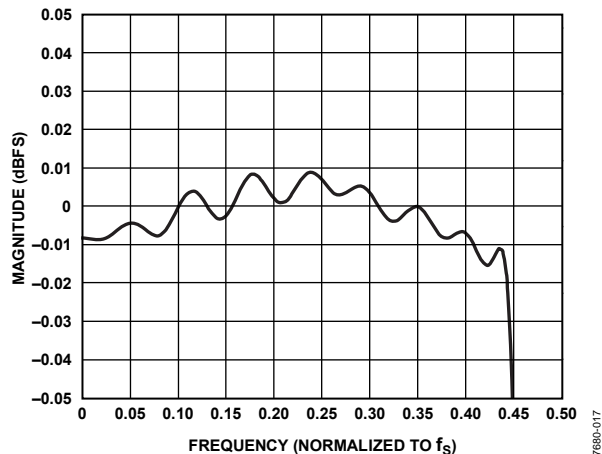

Figure 23. DAC Interpolation Filter Pass-Band Ripple, 128x Oversampling, Normalized to  $f_s$

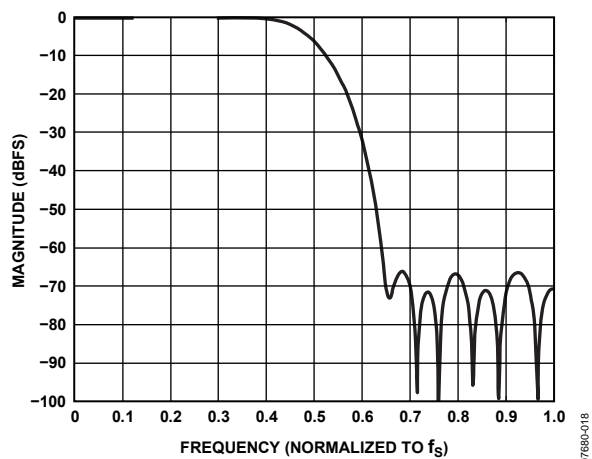

Figure 21. DAC Interpolation Filter, Double-Rate Mode, Normalized to  $f_s$

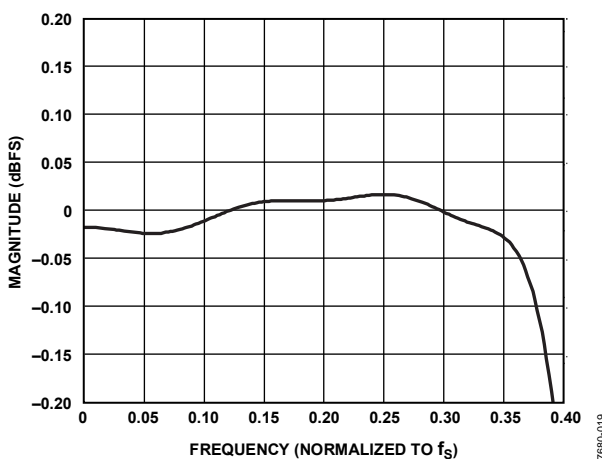

Figure 24. DAC Interpolation Filter Pass-Band Ripple, Double-Rate Mode, Normalized to  $f_s$

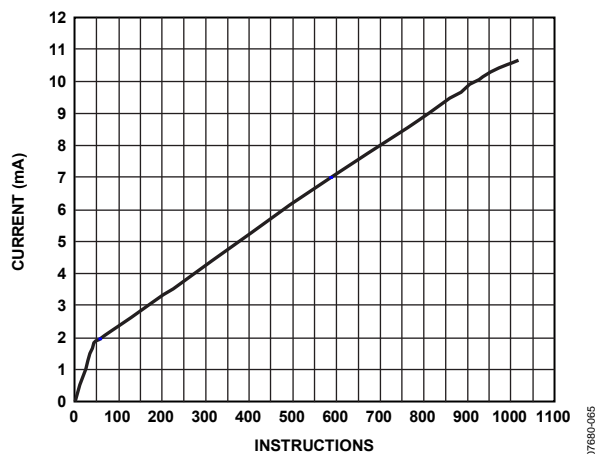

Figure 22. Typical DSP Current Draw

# ADAU1761

## SYSTEM BLOCK DIAGRAMS

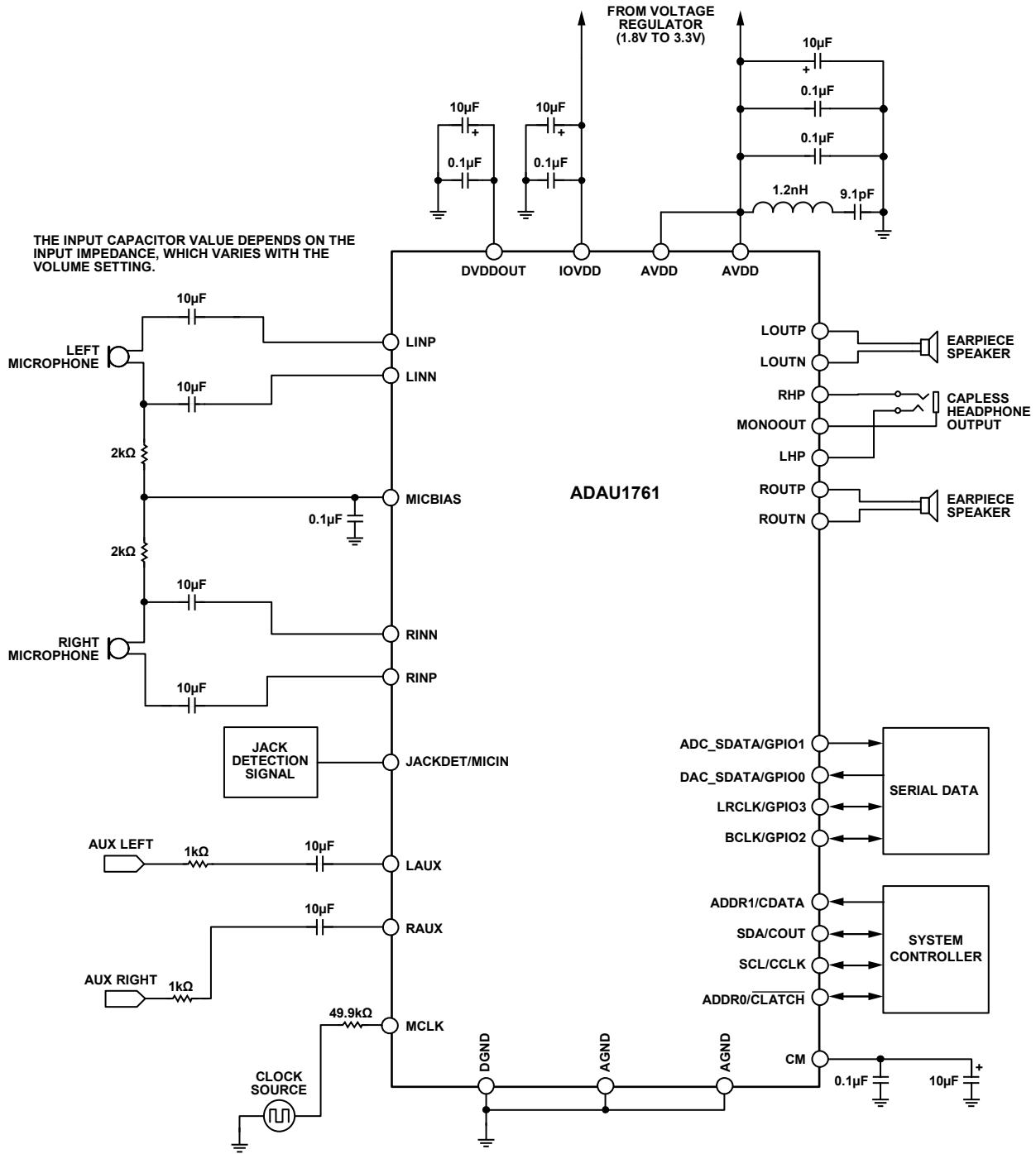

Figure 25. System Block Diagram

07800-045

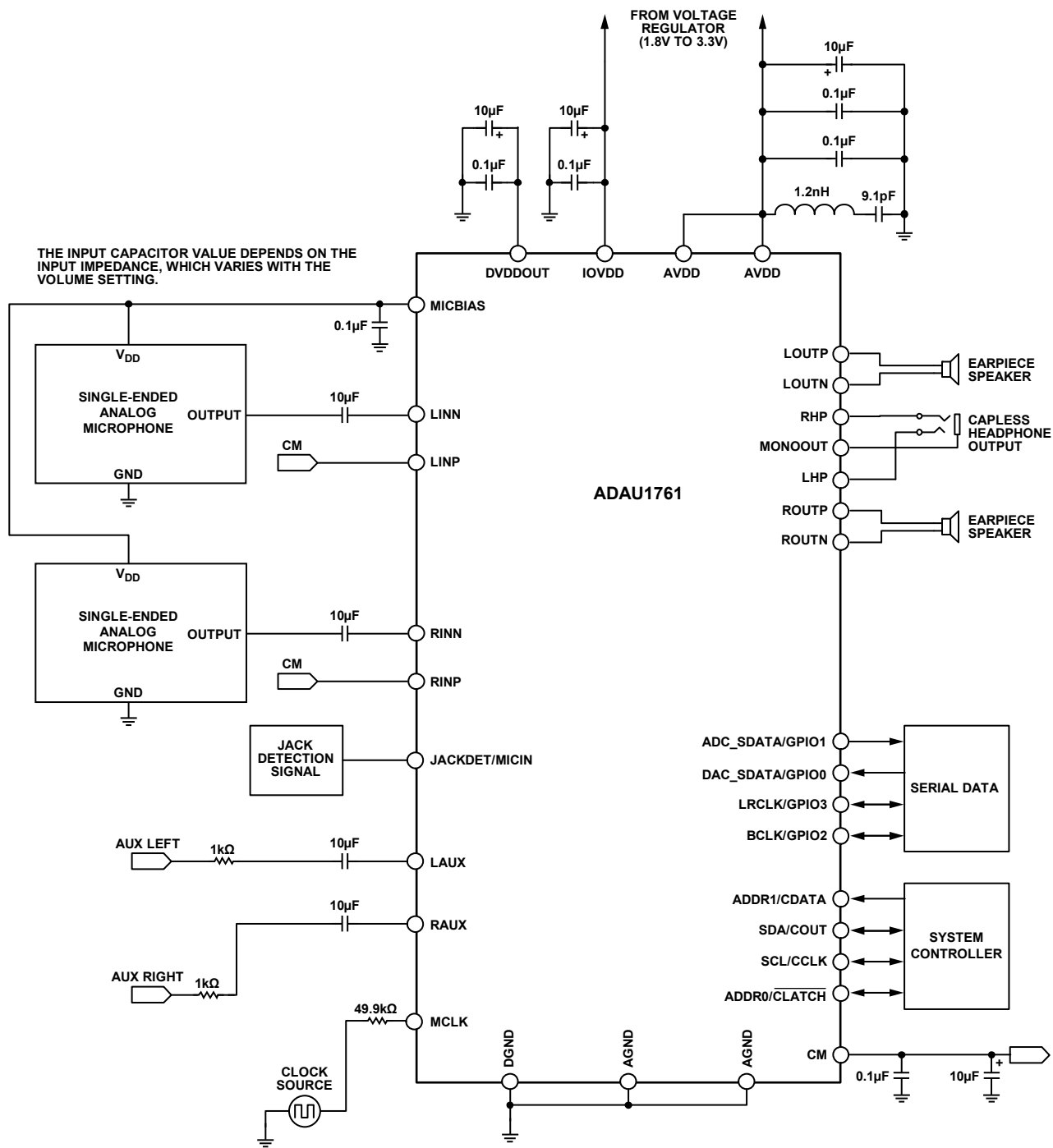

Figure 26. System Block Diagram with Analog Microphones

# ADAU1761

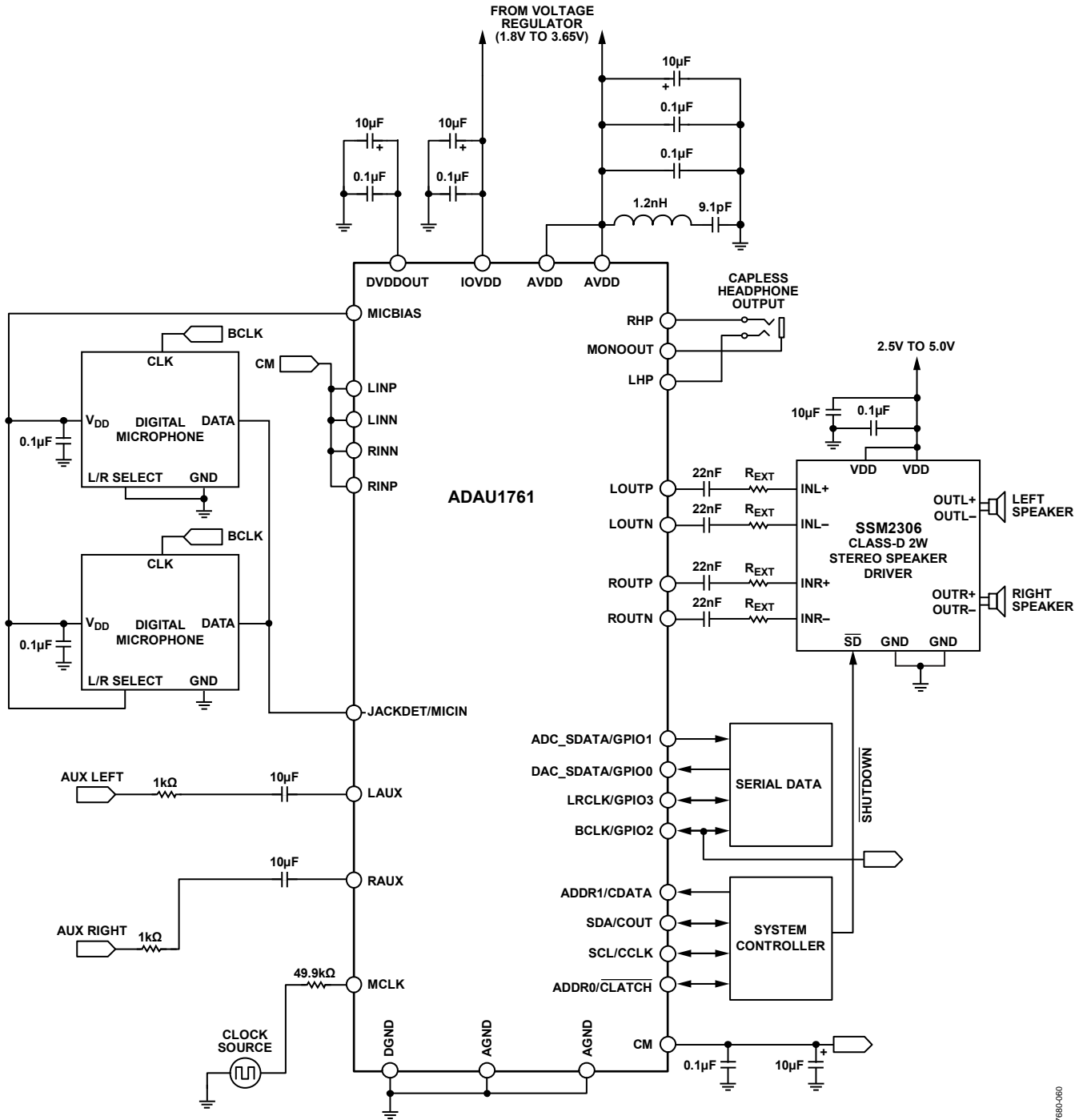

Figure 27. System Block Diagram with Digital Microphones and SSM2306 Class-D Speaker Driver

07860-660

## THEORY OF OPERATION

The ADAU1761 is a low power audio codec with an integrated stream-oriented DSP core, making it an all-in-one package that offers high quality audio, low power, small size, and many advanced features. The stereo ADC and stereo DAC each have an SNR of at least +100 dB and a THD + N of at least -90 dB. The serial data port is compatible with I<sup>2</sup>S, left-justified, right-justified, and TDM modes for interfacing to digital audio data. The operating voltage range is 1.8 V to 3.65 V, with an on-board regulator generating the internal digital supply voltage.

The record signal path includes very flexible input configurations that can accept differential and single-ended analog microphone inputs as well as a digital microphone input. A microphone bias pin provides seamless interfacing to electret microphones. Input configurations can accept up to six single-ended analog signals or variations of stereo differential or stereo single-ended signals with two additional auxiliary single-ended inputs. Each input signal has its own programmable amplifier (PGA) for volume adjustment and can be routed directly to the playback path output mixers, bypassing the ADCs. An automatic level control (ALC) can also be implemented to keep the recording volume constant.

The ADCs and DACs are high quality, 24-bit  $\Sigma$ - $\Delta$  converters that operate at selectable 64 $\times$  or 128 $\times$  oversampling rates. The base sampling rate of the converters is set by the input clock rate and can be further scaled with the converter control register settings. The converters can operate at sampling frequencies from 8 kHz to 96 kHz. The ADCs and DACs also include very fine-step digital volume controls.

The playback path allows input signals and DAC outputs to be mixed into various output configurations. Headphone drivers are available for a stereo headphone output, and the other output pins are capable of differentially driving an earpiece speaker. Capless headphone outputs are possible with the use of the mono output as a virtual ground connection. The stereo line outputs can be used as either single-ended or differential outputs and as an optional mix-down mono output.

The DSP core introduces many features that make this codec unique and optimized for audio processing. The program and parameter RAMs can be loaded with custom audio processing signal flow built using SigmaStudio graphical programming software from Analog Devices, Inc. The values stored in the parameter RAM control individual signal processing blocks, such as equalization filters, dynamics processors, audio delays, and mixer levels.

The SigmaStudio software is used to program and control the SigmaDSP through the control port. Along with designing and tuning a signal flow, the tools can be used to configure all of the DSP registers. The SigmaStudio graphical interface allows anyone with digital or analog audio processing knowledge to easily design DSP signal flow and port it to a target application. At the same time, it provides enough flexibility and programmability for an experienced DSP programmer to have in-depth control of the design. In SigmaStudio, the user can connect graphical blocks (such as biquad filters, dynamics processors, mixers, and delays), compile the design, and load the program and parameter files into the ADAU1761 memory through the control port. Signal processing blocks available in the provided libraries include the following:

- Enhanced stereo capture
- Single- and double-precision biquad filters
- FIR filters
- Dynamics processors with peak or rms detection for mono and multichannel dynamics
- Mixers and splitters
- Tone and noise generators
- Fixed and variable gain
- Loudness
- Delay
- Stereo enhancement
- Dynamic bass boost
- Noise and tone sources
- Level detectors

Additional processing blocks are always being developed. Analog Devices also provides proprietary and third-party algorithms for applications such as matrix decoding, bass enhancement, and surround virtualizers. Contact Analog Devices ([www.analog.com](http://www.analog.com)) for information about licensing these algorithms.

The ADAU1761 can generate its internal clocks from a wide range of input clocks by using the on-board fractional PLL. The PLL accepts inputs from 8 MHz to 27 MHz.

The ADAU1761 is provided in a small, 32-lead, 5 mm  $\times$  5 mm LFCSP with an exposed bottom pad.

## STARTUP, INITIALIZATION, AND POWER

This section describes the procedure for properly starting up the ADAU1761. The following sequence provides a high level approach to the proper initiation of the system.

1. Apply power to the ADAU1761.
2. Lock the PLL with the input clock (if using the PLL).
3. Enable the core clock.
4. Load the register settings.

### POWER-UP SEQUENCE

The ADAU1761 uses a power-on reset (POR) circuit to reset the registers upon power-up. The POR monitors the DVDDOUT pin and generates a reset signal whenever power is applied to the chip. During the reset, the ADAU1761 is set to the default values documented in the register map (see the Control Registers section). Typically, with a 10  $\mu$ F capacitor on AVDD, the POR takes approximately 14 ms.

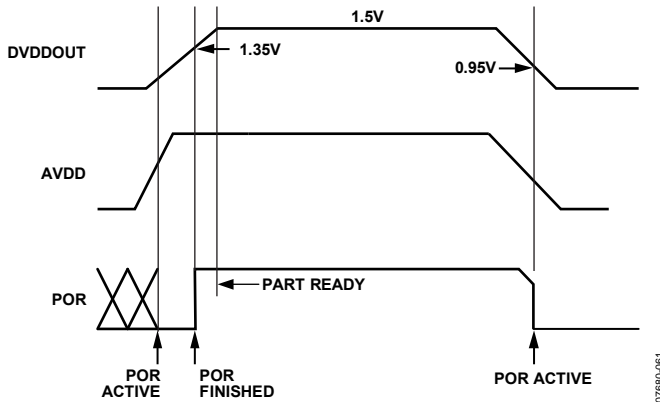

Figure 28. Power-On Reset Sequence

The PLL lock time is dependent on the MCLK rate. Typical lock times are provided in Table 11. The DSP can be enabled immediately after the PLL is locked.

Table 11. PLL Lock Time

PLL Mode	MCLK Frequency	Lock Time (Typical)
Fractional	8 MHz	3.5 ms
Fractional	12 MHz	3.0 ms
Integer	12.288 MHz	2.96 ms
Fractional	13 MHz	2.4 ms
Fractional	14.4 MHz	2.4 ms
Fractional	19.2 MHz	2.98 ms
Fractional	19.68 MHz	2.98 ms
Fractional	19.8 MHz	2.98 ms
Fractional	24 MHz	2.95 ms
Integer	24.576 MHz	2.96 ms
Fractional	26 MHz	2.4 ms
Fractional	27 MHz	2.4 ms

### POWER REDUCTION MODES

Sections of the ADAU1761 chip can be turned on and off as needed to reduce power consumption. These include the ADCs, the DACs, the PLL, and the DSP core.

In addition, the control registers can be used to configure some functions for power saving, normal, or enhanced performance operation. See the Control Registers section for more information.

### DIGITAL POWER SUPPLY

The digital power supply for the ADAU1761 is generated from an internal regulator. This regulator generates a 1.5 V supply internally. The only external connection to this regulator is the DVDDOUT bypassing point. A 100 nF capacitor and a 10  $\mu$ F capacitor should be connected between this pin and DGND.

### INPUT/OUTPUT POWER SUPPLY

The power for the digital output pins is supplied from IOVDD, and this pin also sets the highest input voltage that should be seen on the digital input pins. IOVDD should be set between 1.8 V and 3.3 V; no digital input signal should be at a voltage level higher than the one on IOVDD. The current draw of this pin is variable because it depends on the loads of the digital outputs. IOVDD should be decoupled to DGND with a 100 nF capacitor and a 10  $\mu$ F capacitor.

### CLOCK GENERATION AND MANAGEMENT

The ADAU1761 uses a flexible clocking scheme that enables the use of many different input clock rates. The PLL can be bypassed or used, resulting in two different approaches to clock management. For more information about clocking schemes, PLL configuration, and sampling rates, see the Clocking and Sampling Rates section.

#### Case 1: PLL Is Bypassed

If the PLL is bypassed, the core clock is derived directly from the MCLK input. The rate of this clock must be set properly in Register R0 (clock control register, Address 0x4000) using the INFREQ[1:0] bits. When the PLL is bypassed, supported external clock rates are  $256 \times f_s$ ,  $512 \times f_s$ ,  $768 \times f_s$ , and  $1024 \times f_s$ , where  $f_s$  is the base sampling rate. The core clock of the chip is off until the core clock enable bit (COREN) is asserted.

#### Case 2: PLL Is Used

The core clock to the entire chip is off during the PLL lock acquisition period. The user can poll the lock bit to determine when the PLL has locked. After lock is acquired, the ADAU1761 can be started by asserting the core clock enable bit (COREN) in Register R0 (clock control register, Address 0x4000). This bit enables the core clock to all the internal blocks of the ADAU1761.

***PLL Lock Acquisition***

During the lock acquisition period, only Register R0 (Address 0x4000) and Register R1 (Address 0x4002) are accessible through the control port. Do not attempt to access any other register; any read or write is prohibited until the core clock enable bit (COREN) and the lock bit are both asserted.

To program the PLL during initialization or reconfiguration of the clock setting, the following procedure must be followed:

1. Power down the PLL.
2. Reset the PLL control register.
3. Start the PLL.
4. Poll the lock bit.
5. Assert the core clock enable after the PLL lock is acquired.

The PLL control register (Register R1, Address 0x4002) is a 48-bit register where all bits must be written with a single continuous write to the control port.

## CLOCKING AND SAMPLING RATES

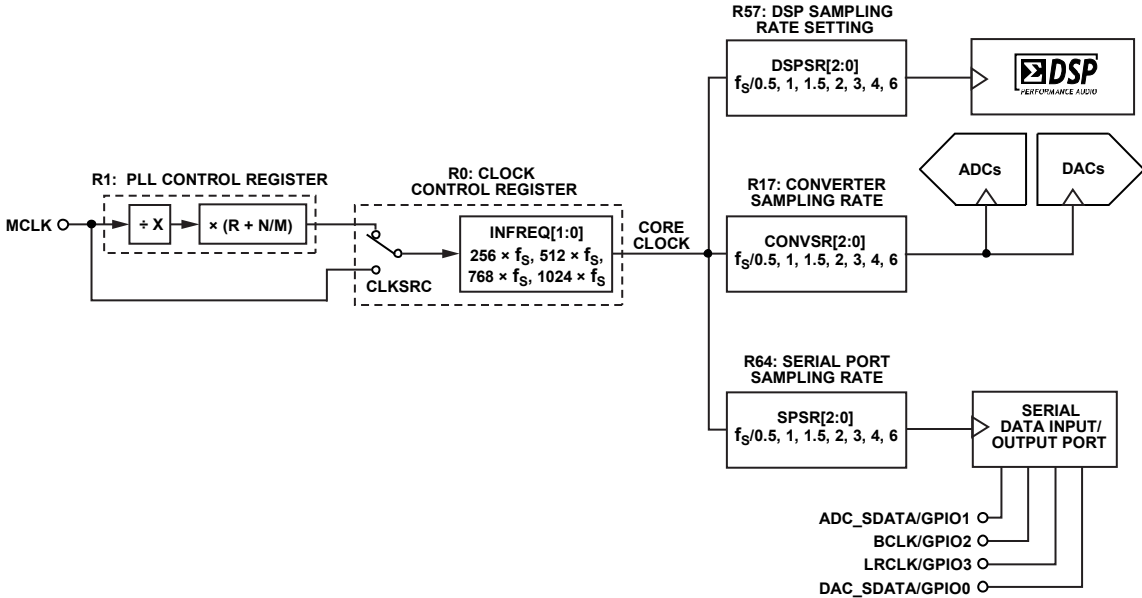

Figure 29. Clock Tree Diagram

### CORE CLOCK

Clocks for the converters, the serial ports, and the DSP are derived from the core clock. The core clock can be derived directly from MCLK or it can be generated by the PLL. The CLKSRC bit (Bit 3 in Register R0, Address 0x4000) determines the clock source.

The INFREQ[1:0] bits should be set according to the expected input clock rate selected by CLKSRC; this value also determines the core clock rate and the base sampling frequency,  $f_s$ .

For example, if the input to CLKSRC = 49.152 MHz (from PLL), then

$$\text{INFREQ}[1:0] = 1024 \times f_s$$

$$f_s = 49.152 \text{ MHz}/1024 = 48 \text{ kHz}$$

PLL output clock rates are always  $1024 \times f_s$  and, in this case, the clock control register automatically sets the INFREQ[1:0] bits to  $1024 \times f_s$  when using the PLL. When using a direct clock, the INFREQ[1:0] frequency should be set according to the MCLK pin clock rate and the desired base sampling frequency.

To utilize the maximum amount of DSP instructions, the core clock should run at a rate of  $1024 \times f_s$ .

Table 12. Clock Control Register (R0: 16384, Address 0x4000)

Bits	Bit Name	Settings
3	CLKSRC	0: Direct from MCLK pin (default) 1: PLL clock
[2:1]	INFREQ[1:0]	00: $256 \times f_s$ (default) 01: $512 \times f_s$ 10: $768 \times f_s$ 11: $1024 \times f_s$
0	COREN	0: Core clock disabled (default) 1: Core clock enabled



### SAMPLING RATES

The ADCs, DACs, and serial port share a common sampling rate that is set in Register R17 (Converter Control 0 register, Address 0x4017). The CONVSR[2:0] bits set the sampling rate as a ratio of the base sampling frequency. The DSP sampling rate is set in Register R57 (DSP sampling rate setting register, Address 0x40EB) using the DSPSR[2:0] bits, and the serial port sampling rate is set in Register R64 (serial port sampling rate register, Address 0x40F8) using the SPSR[2:0] bits.

It is recommended that the sampling rates for the converters, serial ports, and DSP be set to the same value, unless appropriate compensation filtering is done within the DSP. Table 13 and Table 14 list the sampling rate divisions for common base sampling rates.

**Table 13. 48 kHz Base Sampling Rate Divisions**

Base Sampling Frequency	Sampling Rate Scaling	Sampling Rate
$f_s = 48 \text{ kHz}$	$f_s/1$	48 kHz
	$f_s/6$	8 kHz
	$f_s/4$	12 kHz
	$f_s/3$	16 kHz
	$f_s/2$	24 kHz
	$f_s/1.5$	32 kHz
	$f_s/0.5$	96 kHz

**Table 14. 44.1 kHz Base Sampling Rate Divisions**

Base Sampling Frequency	Sampling Rate Scaling	Sampling Rate
$f_s = 44.1 \text{ kHz}$	$f_s/1$	44.1 kHz
	$f_s/6$	7.35 kHz
	$f_s/4$	11.025 kHz
	$f_s/3$	14.7 kHz
	$f_s/2$	22.05 kHz
	$f_s/1.5$	29.4 kHz
	$f_s/0.5$	88.2 kHz

**Table 15. PLL Control Register (Register R1, Address 0x4002)**

Bits	Bit Name	Description
[47:32]	M[15:0]	Denominator of the fractional PLL: 16-bit binary number 0x00FD: M = 253 (default)
[31:16]	N[15:0]	Numerator of the fractional PLL: 16-bit binary number 0x000C: N = 12 (default)
[14:11]	R[3:0]	Integer part of PLL: 4 bits, only values 2 to 8 are valid 0010: R = 2 (default) 0011: R = 3 0100: R = 4 0101: R = 5 0110: R = 6 0111: R = 7 1000: R = 8

### PLL

The PLL uses the MCLK as a reference to generate the core clock. PLL settings are set in Register R1 (PLL control register, Address 0x4002). Depending on the MCLK frequency, the PLL must be set for either integer or fractional mode. The PLL can accept input frequencies in the range of 8 MHz to 27 MHz.

All six bytes in the PLL control register must be written with a single continuous write to the control port.

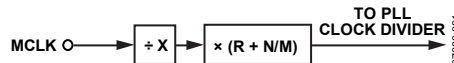

Figure 30. PLL Block Diagram

#### Integer Mode

Integer mode is used when the MCLK is an integer (R) multiple of the PLL output ( $1024 \times f_s$ ).

For example, if MCLK = 12.288 MHz and  $f_s = 48 \text{ kHz}$ , then

$$PLL \text{ required output} = 1024 \times 48 \text{ kHz} = 49.152 \text{ MHz}$$

$$R = 49.152 \text{ MHz} / 12.288 \text{ MHz} = 4$$

In integer mode, the values set for N and M are ignored.

#### Fractional Mode

Fractional mode is used when the MCLK is a fractional ( $R + (N/M)$ ) multiple of the PLL output.

For example, if MCLK = 12 MHz and  $f_s = 48 \text{ kHz}$ , then

$$PLL \text{ required output} = 1024 \times 48 \text{ kHz} = 49.152 \text{ MHz}$$

$$R + (N/M) = 49.152 \text{ MHz} / 12 \text{ MHz} = 4 + (12/125)$$

Common fractional PLL parameter settings for 44.1 kHz and 48 kHz sampling rates can be found in Table 16 and Table 17.

The PLL outputs a clock in the range of 41 MHz to 54 MHz, which should be taken into account when calculating PLL values and MCLK frequencies.

# ADAU1761

Bits	Bit Name	Description
[10:9]	X[1:0]	PLL input clock divider 00: X = 1 (default) 01: X = 2 10: X = 3 11: X = 4
8	Type	PLL operation mode 0: Integer (default) 1: Fractional
1	Lock	PLL lock (read-only bit) 0: PLL unlocked (default) 1: PLL locked
0	PLLEN	PLL enable 0: PLL disabled (default) 1: PLL enabled

**Table 16. Fractional PLL Parameter Settings for  $f_s = 44.1$  kHz (PLL Output = 45.1584 MHz = 1024 ×  $f_s$ )**

MCLK Input (MHz)	Input Divider (X)	Integer (R)	Denominator (M)	Numerator (N)	R2: PLL Control Setting (Hex)
8	1	5	625	403	0x0271 0193 2901
12	1	3	625	477	0x0271 01DD 1901
13	1	3	8125	3849	0x1FBD 0F09 1901
14.4	2	6	125	34	0x007D 0022 3301
19.2	2	4	125	88	0x007D 0058 2301
19.68	2	4	1025	604	0x0401 025C 2301
19.8	2	4	1375	772	0x055F 0304 2301
24	2	3	625	477	0x0271 01DD 1B01
26	2	3	8125	3849	0x1FBD 0F09 1B01
27	2	3	1875	647	0x0753 0287 1B01

**Table 17. Fractional PLL Parameter Settings for  $f_s = 48$  kHz (PLL Output = 49.152 MHz = 1024 ×  $f_s$ )**

MCLK Input (MHz)	Input Divider (X)	Integer (R)	Denominator (M)	Numerator (N)	R2: PLL Control Setting (Hex)
8	1	6	125	18	0x007D 0012 3101
12	1	4	125	12	0x007D 000C 2101
13	1	3	1625	1269	0x0659 04F5 1901
14.4	2	6	75	62	0x004B 003E 3301
19.2	2	5	25	3	0x0019 0003 2B01
19.68	2	4	205	204	0x00CD 00CC 2301
19.8	2	4	825	796	0x0339 031C 2301
24	2	4	125	12	0x007D 000C 2301
26	2	3	1625	1269	0x0659 04F5 1B01
27	2	3	1125	721	0x0465 02D1 1B01

**Table 18. Integer PLL Parameter Settings for  $f_s = 48$  kHz (PLL Output = 49.152 MHz = 1024 ×  $f_s$ )**

MCLK Input (MHz)	Input Divider (X)	Integer (R)	Denominator (M)	Numerator (N)	R2: PLL Control Setting (Hex) <sup>1</sup>
12.288	1	4	Don't care	Don't care	0xFFFF XXXX 2001
24.576	1	2	Don't care	Don't care	0xFFFF XXXX 1001

<sup>1</sup> X = don't care.

## RECORD SIGNAL PATH

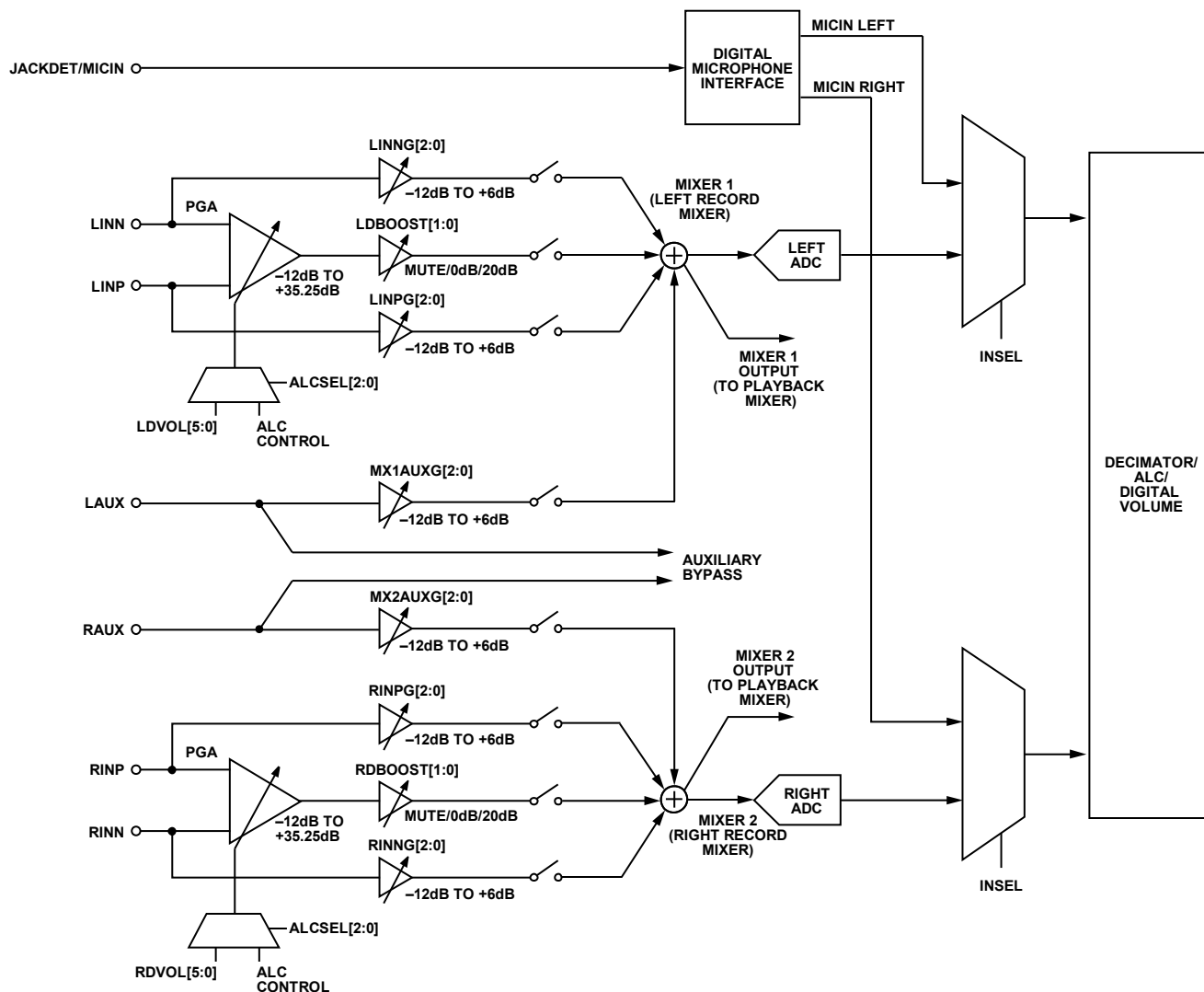

Figure 31. Record Signal Path

### INPUT SIGNAL PATHS

The ADAU1761 can accept both line level and microphone inputs. The analog inputs can be configured in a single-ended or differential configuration. There is also an input for a digital microphone.

Each of the six analog inputs has individual gain controls (boost or cut). The input signals are mixed and routed to an ADC. The mixed input signals can also bypass the ADCs and be routed directly to the playback mixers. Left channel inputs are mixed before the left ADC; however, it is possible to route the mixed analog signal around the ADC and output it into a left or right output channel. The same capabilities apply to the right channel and the right ADC.

### Analog Microphone Inputs

For microphone inputs, configure the part in either stereo pseudo-differential mode or stereo full differential mode.

The LINN and LIMP pins are the inverting and noninverting inputs for the left channel, respectively. The RINN and RIMP pins are the inverting and noninverting inputs for the right channel, respectively.

For a differential microphone input, connect the positive signal to the noninverting input of the PGA and the negative signal to the inverting input of the PGA, as shown in Figure 32. The PGA settings are controlled with Register R8 (left differential input volume control register, Address 0x400E) and Register R9 (right differential input volume control register, Address 0x400F). The PGA must first be enabled by setting the RDEN and LDEN bits.

# ADAU1761

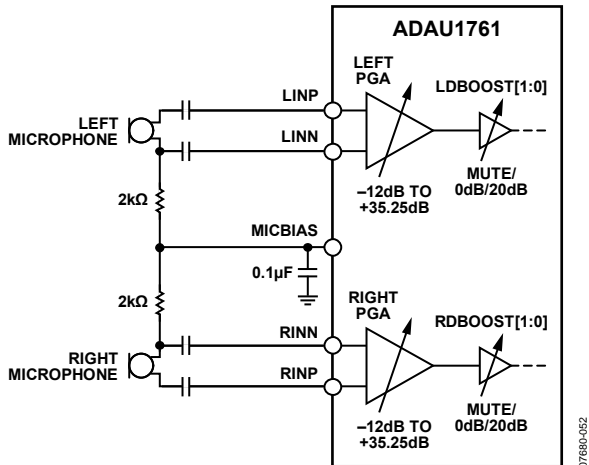

Figure 32. Stereo Differential Microphone Configuration

The PGA can also be used for single-ended microphone inputs. Connect LIMP and/or RIMP to the CM pin. In this configuration, the signal connects to the inverting input of the PGA, LINN and/or RINN, as shown in Figure 33.

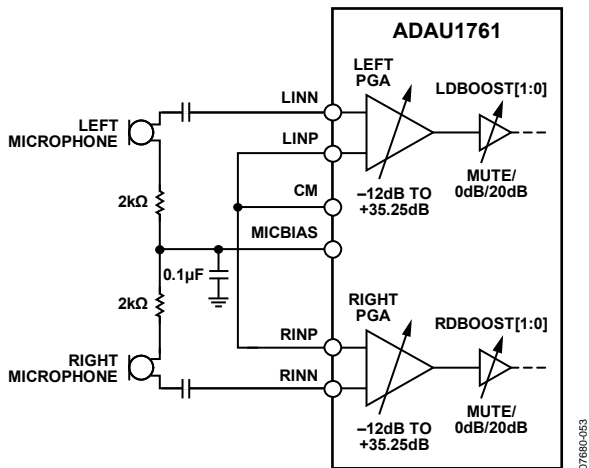

Figure 33. Stereo Single-Ended Microphone Configuration

## Analog Line Inputs

Line input signals can be accepted by any analog input. It is possible to route signals on the RINN, RIMP, LINN, and LIMP pins around the differential amplifier to their own amplifier and to use these pins as single-ended line inputs by disabling the LDEN and RDEN bits (Bit 0 in Register R8, Address 0x400E, and Bit 0 in Register R9, Address 0x400F). Figure 34 depicts a stereo single-ended line input using the RINN and LINN pins.

The LAUX and RAUX pins are single-ended line inputs. They can be used together as a stereo single-ended auxiliary input, as shown in Figure 34. These inputs can bypass the input gain control, mixers, and ADCs to directly connect to the output playback mixers (see auxiliary bypass in Figure 31).

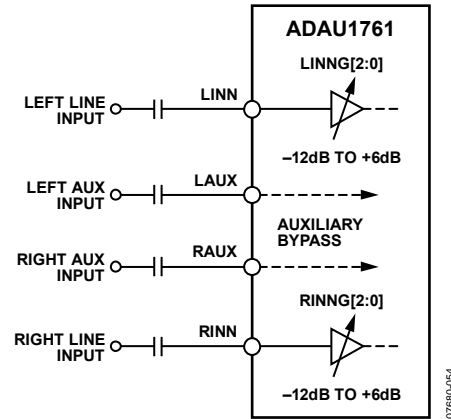

Figure 34. Stereo Single-Ended Line Input with Stereo Auxiliary Bypass

## Digital Microphone Input

When using a digital microphone connected to the JACKDET/MICIN pin, the JDFUNC[1:0] bits in Register R2 (Address 0x4008) must be set to enable the microphone input and disable the jack detection function. The ADAU1761 must operate in master mode and source BCLK to the input clock of the digital microphone. The DSPRUN bit must also be asserted in Register R62 (DSP run register, Address 0x40F6) for digital microphone operation.

The digital microphone signal bypasses record path mixers and ADCs and is routed directly into the decimation filters. The digital microphone and ADCs share decimation filters and, therefore, both cannot be used simultaneously. The digital microphone input select bit, INSEL, can be set in Register R19 (ADC control register, Address 0x4019). Figure 35 depicts the digital microphone interface and signal routing.

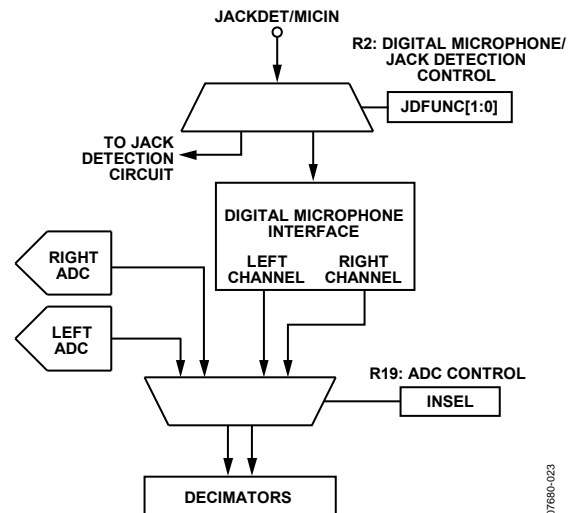

Figure 35. Digital Microphone Interface Block Diagram

**Microphone Bias**

The MICBIAS pin provides a voltage reference for electret analog microphones. The MICBIAS voltage is set in Register R10 (record microphone bias control register, Address 0x4010). In this register, the MICBIAS output can be enabled or disabled. Additional options include high performance operation and a gain boost. The gain boost provides two different voltage biases:  $0.65 \times AVDD$  or  $0.90 \times AVDD$ . When enabled, the high performance bit increases supply current to the microphone bias circuit to decrease rms input noise.

The MICBIAS pin can also be used to cleanly supply voltage to digital microphones or analog microphones with separate power supply pins.

**ANALOG-TO-DIGITAL CONVERTERS**

The ADAU1761 uses two 24-bit  $\Sigma$ - $\Delta$  analog-to-digital converters (ADCs) with selectable oversampling rates of  $64\times$  or  $128\times$  (selected by Bit 3 in Register R17, Address 0x4017).

**ADC Full-Scale Level**

The full-scale input to the ADCs (0 dBFS) depends on AVDD. At AVDD = 3.3 V, the full-scale input level is 1.0 V rms. The full-scale input level scales linearly with the level of AVDD.

For single-ended and pseudo-differential signals, the full-scale value corresponds to the signal level at the pins, 0 dBFS.

Full differential full-scale input is measured after the differential amplifier, which corresponds to  $-6$  dBFS at each pin.

Signal levels above the full-scale value cause the ADCs to clip.

**Digital ADC Volume Control**

The digital ADC volume can be attenuated before DSP processing in Register R20 (left input digital volume register, Address 0x401A) and Register R21 (right input digital volume register, Address 0x401B).

**High-Pass Filter**

By default, a high-pass filter is used in the ADC path to remove dc offsets; this filter can be enabled or disabled in Register R19 (ADC control register, Address 0x4019). At  $f_s = 48$  kHz, the corner frequency of this high-pass filter is 2 Hz.

## AUTOMATIC LEVEL CONTROL (ALC)

The ADAU1761 contains a hardware automatic level control (ALC). The ALC is designed to continuously adjust the PGA gain to keep the recording volume constant as the input level varies.

For optimal noise performance, the ALC uses the analog PGA to adjust the gain instead of using a digital method. This ensures that the ADC noise is not amplified at low signal levels.

Extremely small gain step sizes are used to ensure high audio quality during gain changes.

To use the ALC function, the inputs must be applied either differentially or pseudo-differentially to input pins LINN and LINP, for the left channel, and RINN and RINP, for the right channel. The ALC function is not available for the auxiliary line input pins, LAUX and RAUX.

A block diagram of the ALC block is shown in Figure 36. The PGA logic receives the ADC output signals and analyzes these digital signals to set the PGA gain. The ALC control registers are used to control the time constants and output levels, as described in this section.

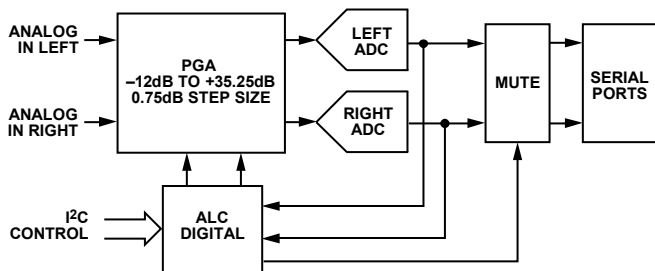

Figure 36. ALC Architecture

### ALC PARAMETERS

The ALC function is controlled with the ALC control registers (Address 0x4011 through Address 0x4014) using the following parameters:

- **ALCSEL[2:0]:** The ALC select bits are used to enable the ALC and set the mode to left only, right only, stereo, or DSP. In stereo mode, the greater of the left or right inputs is used to calculate the gain, and the same gain is then applied to both the left and right channels. In DSP mode, the PGA gain is controlled by the SigmaDSP core.
- **ALCTARG[3:0]:** The ALC target is the desired input recording level that the ALC attempts to achieve.

- **ALCATCK[3:0]:** The ALC attack time sets how fast the ALC starts attenuating after a sudden increase in input level above the ALC target. Although it may seem that the attack time should be set as fast as possible to avoid clipping on transients, using a moderate value results in better overall sound quality. If the value is too fast, the ALC overreacts to very short transients, causing audible gain-pumping effects, which sounds worse than using a moderate value that allows brief periods of clipping on transients. A typical setting for music recording is 384 ms. A typical setting for voice recording is 24 ms.
- **ALCHOLD[3:0]:** These bits set the ALC hold time. When the output signal falls below the target output level, the gain is not increased unless the output remains below the target level for the period of time set by the hold time bits. The hold time is used to prevent the gain from modulating on a steady low frequency sine wave signal, which would cause distortion.
- **ALCDEC[3:0]:** The ALC decay time sets how fast the ALC increases the PGA gain after a sudden decrease in input level below the ALC target. A very slow setting can be used if the main function of the ALC is to set a music recording level. A faster setting can be used if the function of the ALC is to compress the dynamic range of a voice recording. Using a very fast decay time can cause audible artifacts such as noise pumping or distortion. A typical setting for music recording is 24.58 seconds. A typical setting for voice recording is 1.54 seconds.
- **ALCMAX[2:0]:** The maximum ALC gain bits are used to limit the maximum gain that can be programmed into the ALC. This can be used to prevent excessive noise in the recording for small input signals. Note that setting this register to a low value may prevent the ALC from reaching its target output level, but this behavior is often desirable to achieve the best overall sound.

Figure 37 shows the dynamic behavior of the PGA gain for a tone-burst input. The target output is achieved for three different input levels, with the effect of attack, hold, and decay shown in the figure. Note that for very small signals, the maximum PGA gain may prevent the ALC from achieving its target level; in the same way, for very large inputs, the minimum PGA gain may prevent the ALC from achieving its target level (assuming that the target output level is set to a very low value). The effects of the PGA gain limit are shown in the input/output graph of Figure 38.

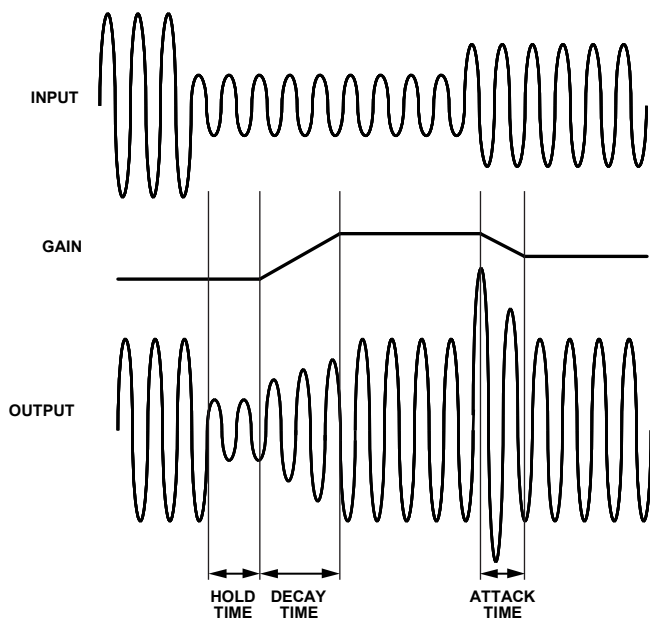

Figure 37. Basic ALC Operation

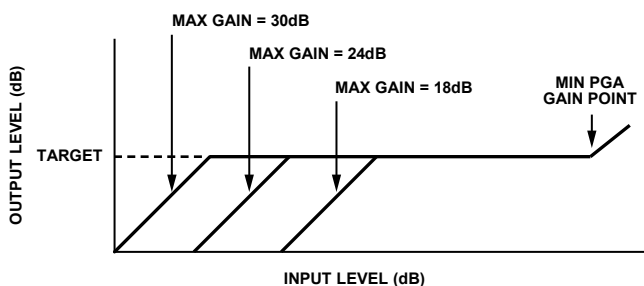

Figure 38. Effect of Varying the Maximum Gain Parameter

### NOISE GATE FUNCTION

When using the ALC, one potential problem is that for small input signals, the PGA gain can become very large. A side effect of this is that the noise is amplified along with the signal of interest. To avoid this situation, the ADAU1761 noise gate can be used. The noise gate cuts off the ADC output when its signal level is below a set threshold. The noise gate is controlled using the following parameters in the ALC Control 3 register (Address 0x4014):

- NGTYP[1:0]: The noise gate type is set to one of four modes by writing to the NGTYP[1:0] bits.
- NGEN: The noise gate function is enabled by writing to the NGEN bit.
- NGTHR[4:0]: The threshold for muting the output is set by writing to the NGTHR[4:0] bits.

One common problem with noise gate functions is chatter, where a small signal that is close to the noise gate threshold varies in amplitude, causing the noise gate function to open and close rapidly. This causes an unpleasant sound.

To reduce this effect, the noise gate in the ADAU1761 uses a combination of a timeout period and hysteresis. The timeout period is set to 250 ms, so the signal must consistently be below

the threshold for 250 ms before the noise gate operates. Hysteresis is used so that the threshold for coming out of the mute state is 6 dB higher than the threshold for going into the mute state. There are four operating modes for the noise gate.

Noise Gate Mode 0 (see Figure 39) is selected by setting the NGTYP[1:0] bits to 00. In this mode, the current state of the PGA gain is held at its current state when the noise gate logic is activated. This prevents a large increase in background noise during periods of silence. When using this mode, it is advisable to use a relatively slow decay time. This is because the noise gate takes at least 250 ms to activate, and if the PGA gain has already increased to a large value during this time, the value at which the gain is held will be large.

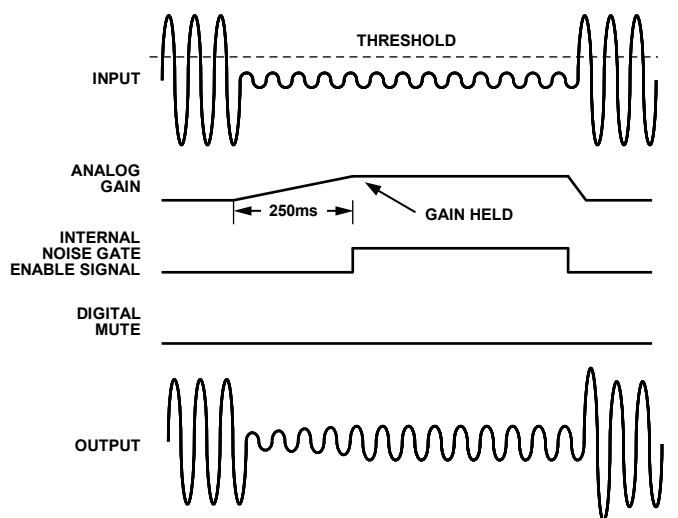

Figure 39. Noise Gate Mode 0 (PGA Gain Hold)

Noise Gate Mode 1 (see Figure 40) is selected by setting the NGTYP[1:0] bits to 01. In this mode, the ADAU1761 does a simple digital mute of the ADC output. Although this mode completely eliminates any background noise, the effect of an abrupt mute may not be pleasant to the ear.

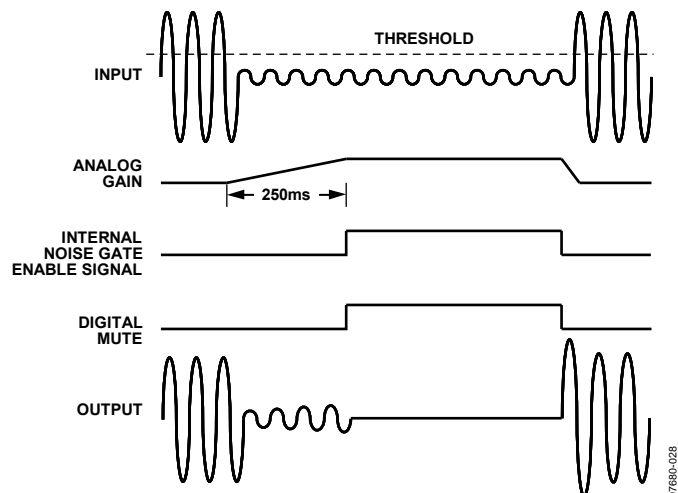

Figure 40. Noise Gate Mode 1 (Digital Mute)

# ADAU1761

Noise Gate Mode 2 (see Figure 41) is selected by setting the NGTYP[1:0] bits to 10. In this mode, the ADAU1761 improves the sound of the noise gate operation by first fading the PGA gain over a period of about 100 ms to the minimum PGA gain value. The ADAU1761 does not do a hard mute after the fade is complete, so some small background noise will still exist.

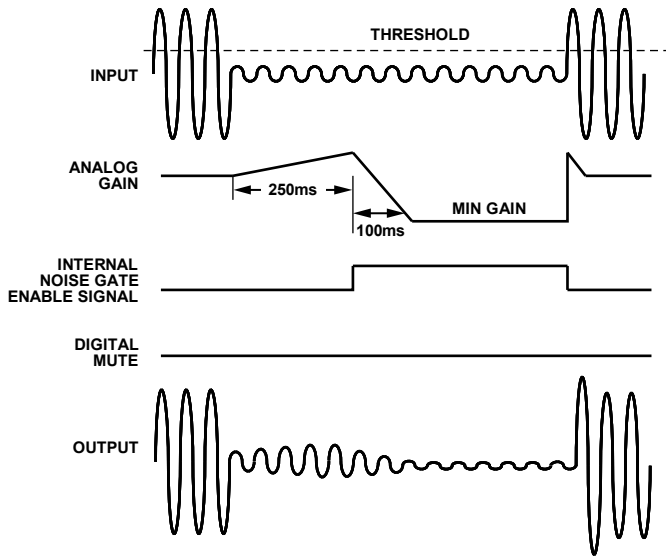

Figure 41. Noise Gate Mode 2 (Analog Fade)

Noise Gate Mode 3 (see Figure 42) is selected by setting the NGTYP[1:0] bits to 11. This mode is the same as Mode 2 except that at the end of the PGA fade gain interval, a digital mute is performed. In general, this mode is the best-sounding mode, because the audible effect of the digital hard mute is reduced by the fact that the gain has already faded to a low level before the mute occurs.

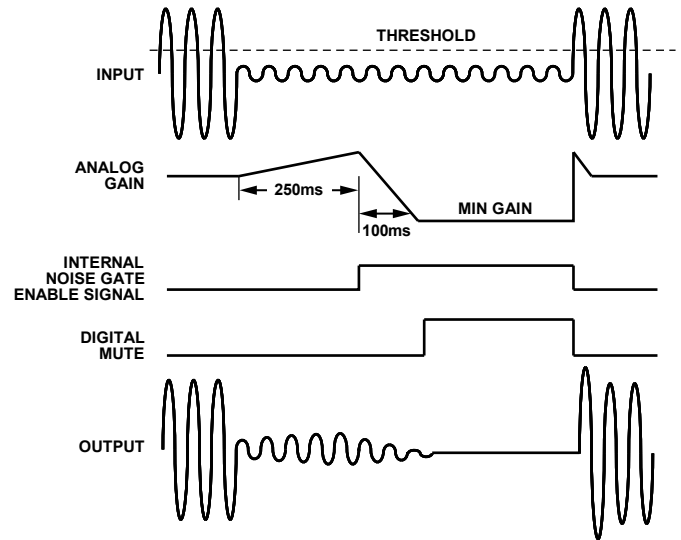

Figure 42. Noise Gate Mode 3 (Analog Fade/Digital Mute)



## PLAYBACK SIGNAL PATH

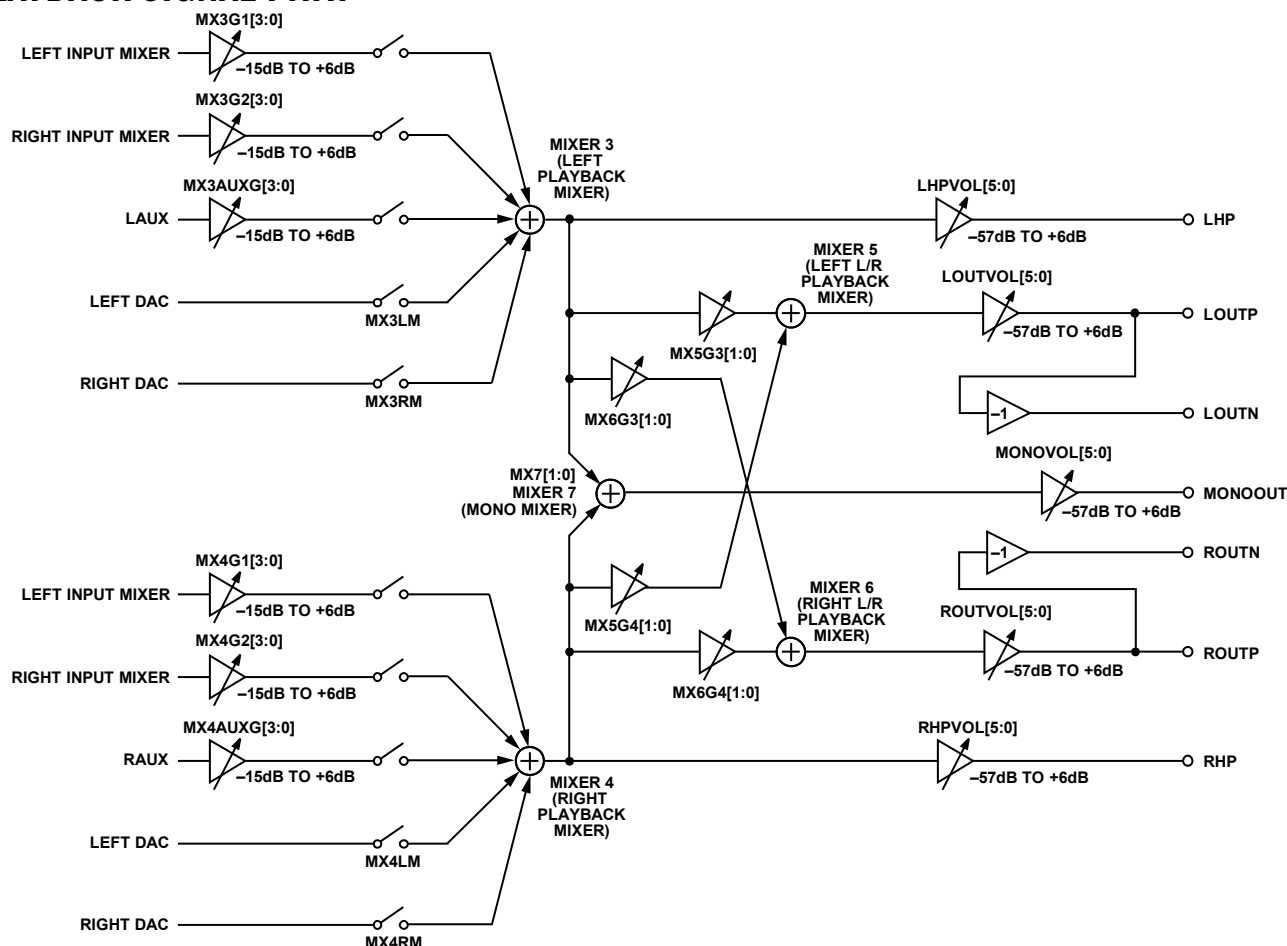

Figure 43. Playback Signal Path

07680-031

## OUTPUT SIGNAL PATHS

The outputs of the ADAU1761 can be configured as a variety of differential or single-ended outputs. All analog output pins are capable of driving headphone or earpiece speakers. There are selectable output paths for stereo signals or a downmixed mono output. The line outputs can drive a load of at least 10 kΩ or can be put into HP mode to drive headphones or earpiece speakers.

### Routing Flexibility

The playback path contains five mixers (Mixer 3 to Mixer 7) that perform the following functions:

- Mix signals from the record path and the DACs.
- Mix or swap the left and right channels.
- Mix a mono signal or generate a common-mode output.

Mixer 3 and Mixer 4 are dedicated to mixing signals from the record path and the DACs. Each of these two mixers can accept signals from the left and right DACs, the left and right input mixers, and the dedicated channel auxiliary input. Signals coming from the record path can be boosted or cut before the playback mixer.

For example, the MX4G2[3:0] bits set the gain from the output of Mixer 2 (right record channel) to the input of Mixer 4, hence the naming convention.

Signals coming from the DACs have digital volume attenuation controls set in Register R20 (left input digital volume register, Address 0x401A) and Register R21 (right input digital volume register, Address 0x401B).

## HEADPHONE OUTPUT

The LHP and RHP pins can be driven by either a line output driver or a headphone driver by setting the HPMODE bit in Register R30 (playback headphone right volume control register, Address 0x4024). The headphone outputs can drive a load of at least 16 Ω.

There are separate volume controls for the left and right channels that can also be linked for dual control using the HPDUAL bit in Register R29 (playback headphone left volume control register, Address 0x4023). The volume controls for these outputs range from -57 dB to +6 dB. Slew can be applied to all the playback volume controls using the ASLEW[1:0] bits in Register R34 (playback pop/click suppression register, Address 0x4028).

## Capless Headphone Configuration

The headphone outputs can be configured in a capless output configuration with the MONOOUT pin used as a dc virtual ground reference. Figure 44 depicts a typical playback path in a capless headphone configuration. Table 19 lists the register settings for this configuration. As shown in this table, the MONOOUT pin outputs common mode (AVDD/2), which is used as the virtual headphone reference.

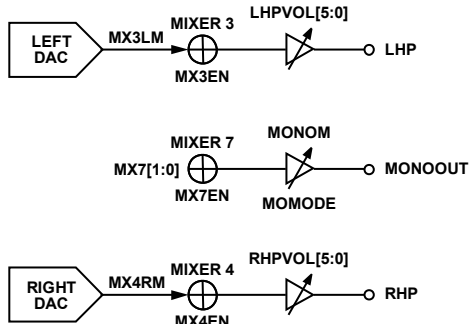

Figure 44. Capless Headphone Configuration Diagram

Table 19. Capless Headphone Register Settings

Register	Bit Name	Setting
R36	DACEN[1:0]	11 = both DACs on
R22	MX3EN	1 = enable Mixer 3
R24	MX3LM	1 = unmute left DAC input
	MX4EN	1 = enable Mixer 4
R28	MX4RM	1 = unmute right DAC input
	MX7EN	1 = enable Mixer 7
R33	MX7[1:0]	00 = common-mode output
	MONOM	1 = unmute mono output
R29	MOMODE	1 = headphone output
	LHPVOL[5:0]	Desired volume for LHP output
R30	LHPM	1 = unmute left headphone output
	HPMODE	1 = headphone output
	RHPVOL[5:0]	Desired volume for RHP output
	RHPM	1 = unmute right headphone output

## Headphone Output Power-Up/Power-Down Sequencing

To prevent pops when turning on the headphone outputs, the user must wait at least 4 ms to unmute these outputs after enabling the headphone output with the HPMODE bit. This is because of an internal capacitor that must charge before these outputs can be used. Figure 45 and Figure 46 illustrate the headphone power-up/power-down sequencing.

For capless headphones, configure the MONOOUT pin before unmuting the headphone outputs.

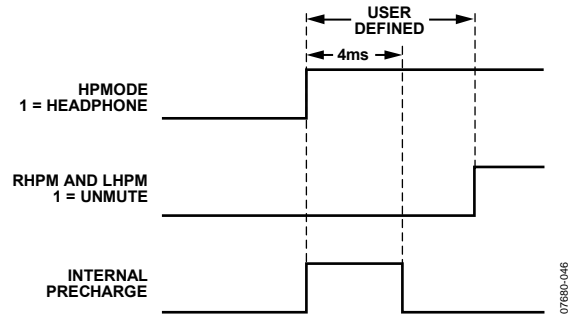

Figure 45. Headphone Output Power-Up Timing

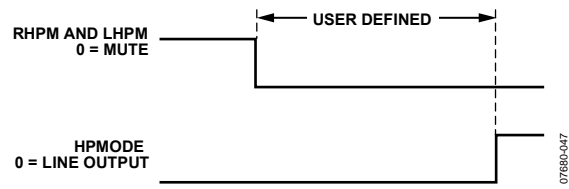

Figure 46. Headphone Output Power-Down Timing

## Ground-Centered Headphone Configuration

The headphone outputs can also be configured as ground-centered outputs by placing coupling capacitors on the LHP and RHP pins. Ground-centered headphones should use the AGND pin as the ground reference.

When the headphone outputs are configured in this manner, the capacitors create a high-pass filter on the outputs. The corner frequency of this filter, at which point its attenuation is 3 dB, is calculated by the following formula:

$$f_{3dB} = 1/(2\pi \times R \times C)$$

where :

C is the capacitor value.

R is the impedance of the headphones.

For a typical headphone impedance of 16 Ω and a 47 μF capacitor, the corner frequency is 211 Hz.

## Jack Detection

When the JACKDET/MICIN pin is set to the jack detect function, a flag on this pin can be used to mute the line outputs when headphones are plugged into their jacks. This pin can be configured in Register R2 (digital microphone/jack detection control register, Address 0x4008). The JDFUNC[1:0] bits set the functionality of the JACKDET/MICIN pin.

The JDMUTE bit enables a line output muting function, which mutes all of the line outputs when a headphone jack is detected. When headphones are unplugged from the jack, the headphone driver and outputs are muted.

Additional settings for jack detection include debounce time (JDDB[1:0] bits) and detection polarity (JDPOL bit). Because the jack detection and digital microphone share a pin, both functions cannot be used simultaneously.

**Pop-and-Click Suppression**

Upon power-up, precharge circuitry is enabled to suppress pops and clicks. After power-up, the precharge circuitry can be put into a low power mode using the POPMODE bit in Register R34 (playback pop/click suppression register, Address 0x4028).

The precharge time depends on the capacitor value on the CM pin and the RC time constant of the load. For a typical line output load, the precharge time is between 2 ms and 3 ms. After this precharge time, the POPMODE bit can be set to low power mode.

**LINE OUTPUTS**

The line output pins (LOUTP, LOUTN, ROUTP, and ROUTN) can be used to drive both differential and single-ended loads. In their default settings, these pins can drive typical line loads of 10 kΩ or greater, but they can also be put into headphone mode by setting the LOMODE bit in Register R31 (playback line output left volume control register, Address 0x4025) and the ROMODE bit in Register R32 (playback line output right volume control register, Address 0x4026). In headphone mode, the line output pins are capable of driving headphone and earpiece speakers of 16 Ω or greater.

When the line output pins are used in single-ended mode, LOUTP and ROUTP should be used to output the signals, and LOUTN and ROUTN should be left disconnected.

The volume controls for these outputs range from -57 dB to +6 dB. Slew can be applied to all the playback volume controls using the ASLEW[1:0] bits in Register R34 (playback pop/click suppression register, Address 0x4028).

The MX5G4[1:0], MX5G3[1:0], MX6G3[1:0], and MX6G4[1:0] bits can all provide a 6 dB gain boost to the line outputs. This gain boost allows single-ended output signals to achieve 0 dBV (1.0 V rms) and differential output signals to achieve up to 6 dBV (2.0 V rms). For more information, see Register R26 (playback L/R mixer left (Mixer 5) line output control register, Address 0x4020) and Register R27 (playback L/R mixer right (Mixer 6) line output control register, Address 0x4021).

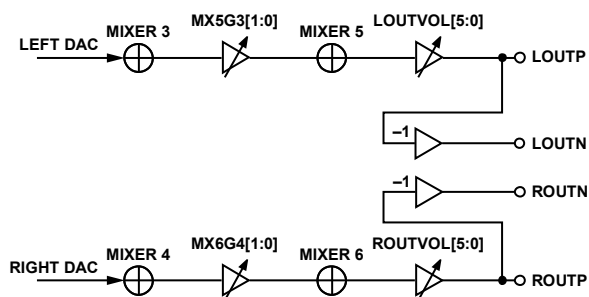

Figure 47. Differential Line Output Configuration

07980-018

## CONTROL PORTS

The ADAU1761 can operate in one of two control modes:

- I<sup>2</sup>C control
- SPI control

The ADAU1761 has both a 4-wire SPI control port and a 2-wire I<sup>2</sup>C bus control port. Both ports can be used to set the registers. The part defaults to I<sup>2</sup>C mode, but it can be put into SPI control mode by pulling the  $\overline{\text{CLATCH}}$  pin low three times.

The control port is capable of full read/write operation for all addressable registers. Operations such as mute and input/output mode control are programmed by writing to these registers.

All addresses can be accessed in both a single-address mode or a burst mode. The first byte (Byte 0) of a control port write contains the 7-bit chip address plus the  $\overline{\text{R/W}}$  bit. The next two bytes (Byte 1 and Byte 2) together form the subaddress of the register location within the ADAU1761. This subaddress must be two bytes long because the memory locations within the ADAU1761 are directly addressable and their sizes exceed the range of single-byte addressing. All subsequent bytes (starting with Byte 3) contain the data, such as control port data, program data, or parameter data. The number of bytes per word depends on the type of data that is being written.

The ADAU1761 has several mechanisms for updating signal processing parameters in real time without causing pops or clicks. If large blocks of data need to be downloaded, the output of the DSP core can be halted (using the DSPRUN bit in the DSP run register, Address 0x40F6), new data can be loaded, and the device can be restarted. This is typically done during the booting sequence at start-up or when loading a new program into RAM.

The control port pins are multifunctional, depending on the mode in which the part is operating. Table 20 describes these multiple functions.

**Table 20. Control Port Pin Functions**

Pin Name	I <sup>2</sup> C Mode	SPI Mode
SCL/CCLK	SCL: input clock	CCLK: input clock
SDA/COUT	SDA: open-collector input/output	COUT: output
ADDR1/CDATA	I <sup>2</sup> C Address Bit 1: input	CDATA: input
ADDR0/ $\overline{\text{CLATCH}}$	I <sup>2</sup> C Address Bit 0: input	$\overline{\text{CLATCH}}$ : input

### I<sup>2</sup>C PORT

The ADAU1761 supports a 2-wire serial (I<sup>2</sup>C-compatible) microprocessor bus driving multiple peripherals. Two pins, serial data (SDA) and serial clock (SCL), carry information between the ADAU1761 and the system I<sup>2</sup>C master controller.

In I<sup>2</sup>C mode, the ADAU1761 is always a slave on the bus, meaning that it cannot initiate a data transfer. Each slave device is recognized by a unique address. The address and  $\overline{\text{R/W}}$  byte format is shown in Table 21. The address resides in the first seven bits of the I<sup>2</sup>C write. Bits[5:6] of the I<sup>2</sup>C address for the ADAU1761 are set by the levels on the ADDR1 and ADDR0 pins. The LSB of the address—the  $\overline{\text{R/W}}$  bit—specifies either a read or write operation. Logic Level 1 corresponds to a read operation, and Logic Level 0 corresponds to a write operation.

**Table 21. ADAU1761 I<sup>2</sup>C Address and Read/Write Byte Format**

Bit 0	Bit 1	Bit 2	Bit 3	Bit 4	Bit 5	Bit 6	Bit 7
0	1	1	1	0	ADDR1	ADDR0	$\overline{\text{R/W}}$

Burst mode addressing, where the subaddresses are automatically incremented at word boundaries, can be used for writing large amounts of data to contiguous registers. This increment happens automatically after a single-word write unless a stop condition is encountered. The registers in the ADAU1761 are one byte wide with the exception of the PLL control register, which is six bytes wide, so the autoincrement feature knows the mapping between subaddresses and the word length of the destination register. A data transfer is always terminated by a stop condition.

The SDA and SCL pins should each have a 2 k $\Omega$  pull-up resistor on the line connected to it. The voltage on these signal lines should not be more than IOVDD (1.8 V to 3.3 V).

### Addressing

Initially, each device on the I<sup>2</sup>C bus is in an idle state and monitors the SDA and SCL lines for a start condition and the proper address. The I<sup>2</sup>C master initiates a data transfer by establishing a start condition, defined by a high-to-low transition on SDA while SCL remains high. This indicates that an address/data stream follows. All devices on the bus respond to the start condition and shift the next eight bits (the 7-bit address plus the  $\overline{\text{R/W}}$  bit) MSB first. The device that recognizes the transmitted address responds by pulling the data line low during the ninth clock pulse. This ninth bit is known as an acknowledge bit. All other devices withdraw from the bus at this point and return to the idle condition.

The  $\overline{\text{R/W}}$  bit determines the direction of the data. A Logic 0 on the LSB of the first byte means that the master will write information to the peripheral, whereas a Logic 1 means that the master will read information from the peripheral after writing the subaddress and repeating the start address. A data transfer takes place until a stop condition is encountered. A stop condition occurs when SDA transitions from low to high while SCL is held high. Figure 48 shows the timing of an I<sup>2</sup>C write, and Figure 49 shows an I<sup>2</sup>C read.

Stop and start conditions can be detected at any stage during the data transfer. If these conditions are asserted out of sequence with normal read and write operations, the ADAU1761 immediately jumps to the idle condition. During a given SCL high period, the user should only issue one start condition, one stop condition, or a single stop condition followed by a single start condition. If an invalid subaddress is issued by the user, the ADAU1761 does not issue an acknowledge and returns to the idle condition.

If the user exceeds the highest subaddress while in autoincrement mode, one of two actions is taken. In read mode, the ADAU1761 outputs the highest subaddress register contents until the master device issues a no acknowledge, indicating the end of a read. A no acknowledge condition is where the SDA line is not pulled low on the ninth clock pulse on SCL. If the highest subaddress location is reached while in write mode, the data for the invalid byte is not loaded into any subaddress register, a no acknowledge is issued by the ADAU1761, and the part returns to the idle condition.

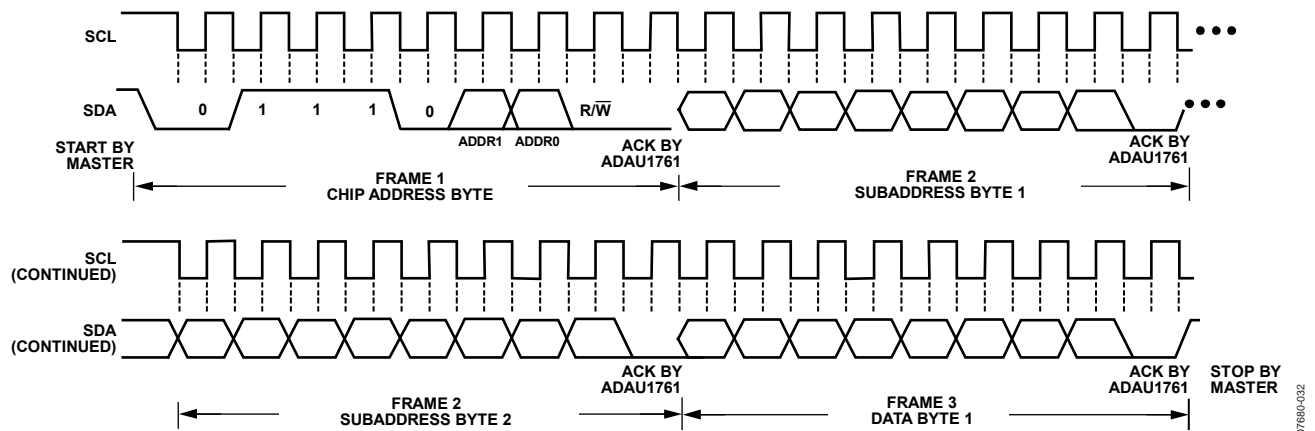

Figure 48. I<sup>2</sup>C Write to ADAU1761 Clcking

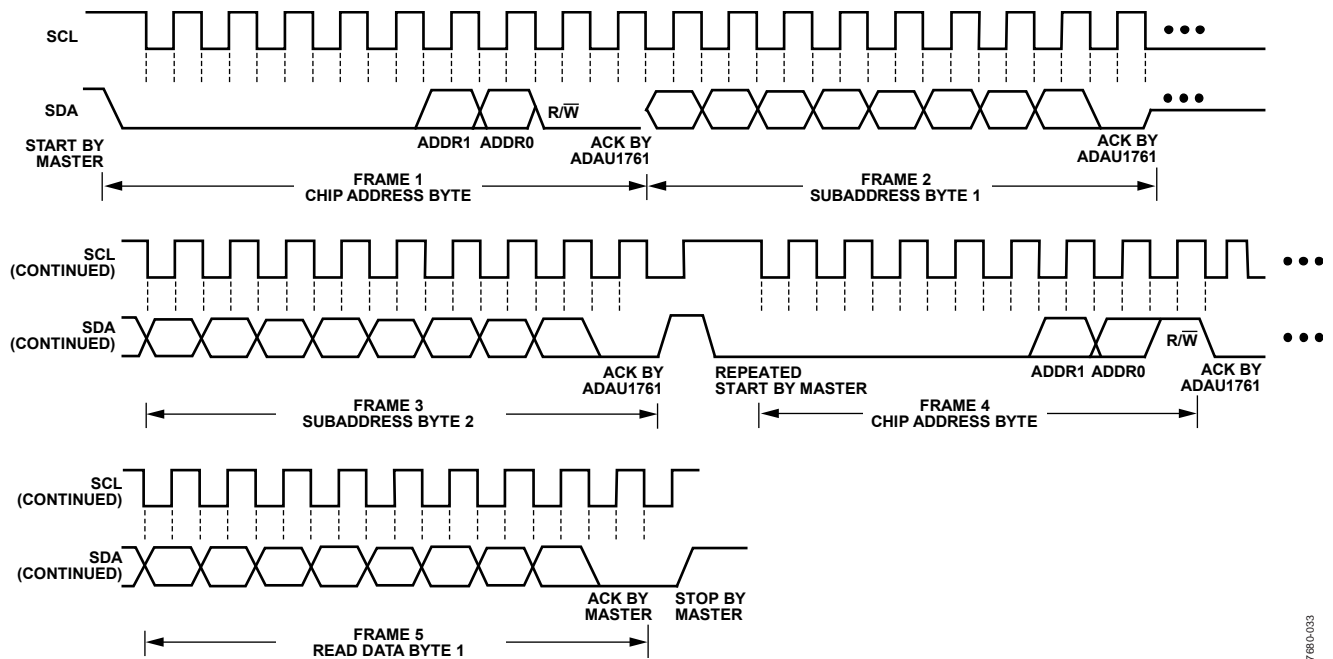

Figure 49. I<sup>2</sup>C Read from ADAU1761 Clcking

# ADAU1761

## I<sup>2</sup>C Read and Write Operations

Figure 50 shows the format of a single-word write operation. Every ninth clock pulse, the ADAU1761 issues an acknowledge by pulling SDA low.

Figure 51 shows the format of a burst mode write sequence. This figure shows an example of a write to sequential single-byte registers. The ADAU1761 increments its subaddress register after every byte because the requested subaddress corresponds to a register or memory area with a 1-byte word length.

Figure 52 shows the format of a single-word read operation. Note that the first R/W bit is 0, indicating a write operation. This is because the subaddress still needs to be written to set up the internal address. After the ADAU1761 acknowledges the receipt of the subaddress, the master must issue a repeated start command followed by the chip address byte with the R/W bit set to 1 (read).

This causes the ADAU1761 SDA to reverse and begin driving data back to the master. The master then responds every ninth pulse with an acknowledge pulse to the ADAU1761.

Figure 53 shows the format of a burst mode read sequence. This figure shows an example of a read from sequential single-byte registers. The ADAU1761 increments its subaddress register after every byte because the requested subaddress corresponds to a register or memory area with a 1-byte word length. The ADAU1761 always decodes the subaddress and sets the auto-increment circuit so that the address increments after the appropriate number of bytes.

Figure 50 to Figure 53 use the following abbreviations:

S = start bit

P = stop bit

AM = acknowledge by master

AS = acknowledge by slave

S	Chip address, R/W = 0	AS	Subaddress high	AS	Subaddress low	AS	Data Byte 1	P
---	--------------------------	----	-----------------	----	----------------	----	-------------	---

Figure 50. Single-Word I<sup>2</sup>C Write Format

S	Chip address, R/W = 0	AS	Subaddress high	AS	Subaddress low	AS	Data Byte 1	AS	Data Byte 2	AS	Data Byte 3	AS	Data Byte 4	AS	...	P
---	--------------------------	----	--------------------	----	-------------------	----	----------------	----	----------------	----	----------------	----	----------------	----	-----	---

Figure 51. Burst Mode I<sup>2</sup>C Write Format

S	Chip address, R/W = 0	AS	Subaddress high	AS	Subaddress low	AS	S	Chip address, R/W = 1	AS	Data Byte 1	P
---	--------------------------	----	-----------------	----	----------------	----	---	--------------------------	----	----------------	---

Figure 52. Single-Word I<sup>2</sup>C Read Format

S	Chip address, R/W = 0	AS	Subaddress high	AS	Subaddress low	AS	S	Chip address, R/W = 1	AS	Data Byte 1	AM	Data Byte 2	AM	...	P
---	--------------------------	----	--------------------	----	-------------------	----	---	--------------------------	----	----------------	----	----------------	----	-----	---

Figure 53. Burst Mode I<sup>2</sup>C Read Format

### SPI PORT

By default, the ADAU1761 is in I<sup>2</sup>C mode, but it can be put into SPI control mode by pulling  $\overline{\text{CLATCH}}$  low three times. The SPI port uses a 4-wire interface, consisting of  $\overline{\text{CLATCH}}$ , CCLK, CDATA, and COUT signals, and it is always a slave port. The  $\overline{\text{CLATCH}}$  signal should go low at the beginning of a transaction and high at the end of a transaction. The CCLK signal latches CDATA on a low-to-high transition. COUT data is shifted out of the ADAU1761 on the falling edge of CCLK and should be clocked into a receiving device, such as a microcontroller, on the CCLK rising edge. The CDATA signal carries the serial input data, and the COUT signal is the serial output data. The COUT signal remains three-state until a read operation is requested. This allows other SPI-compatible peripherals to share the same readback line. All SPI transactions have the same basic format shown in Table 23. A timing diagram is shown in Figure 4. All data should be written MSB first. The ADAU1761 can be taken out of SPI mode only by a full reset initiated by power-cycling the IC.

#### Chip Address R/W

The LSB of the first byte of an SPI transaction is a R/W bit. This bit determines whether the communication is a read (Logic Level 1) or a write (Logic Level 0). This format is shown in Table 22.

Table 22. ADAU1761 SPI Address and Read/Write Byte Format

Bit 0	Bit 1	Bit 2	Bit 3	Bit 4	Bit 5	Bit 6	Bit 7
0	0	0	0	0	0	0	R/W

#### Subaddress

The 16-bit subaddress word is decoded into a location in one of the registers. This subaddress is the location of the appropriate register. The MSBs of the subaddress are zero-padded to bring the word to a full 2-byte length.

#### Data Bytes

The number of data bytes varies according to the register being accessed. During a burst mode write, an initial subaddress is written followed by a continuous sequence of data for consecutive register locations.

A sample timing diagram for a single-word SPI write operation to a register is shown in Figure 54. A sample timing diagram of a single-word SPI read operation is shown in Figure 55. The COUT pin goes from being three-state to being driven at the beginning of Byte 3. In this example, Byte 0 to Byte 2 contain the addresses and R/W bit, and subsequent bytes carry the data.

Table 23. Generic Control Word Format

Byte 0	Byte 1	Byte 2	Byte 3	Byte 4 <sup>1</sup>
chip_adr[6:0], R/W	subaddr[15:8]	subaddr[7:0]	data	data

<sup>1</sup> Continues to end of data.

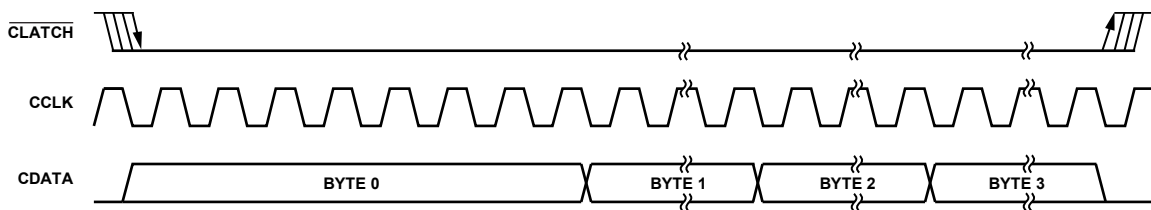

Figure 54. SPI Write to ADAU1761 Clocking (Single-Word Write Mode)

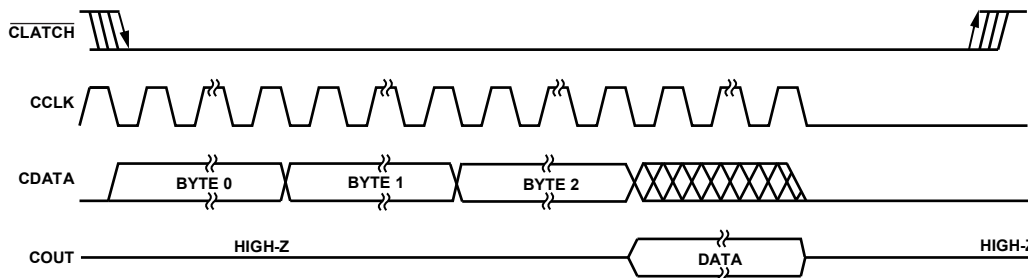

Figure 55. SPI Read from ADAU1761 Clocking (Single-Word Read Mode)

## SERIAL DATA INPUT/OUTPUT PORTS

The flexible serial data input and output ports of the ADAU1761 can be set to accept or transmit data in 2-channel format or in a 4-channel or 8-channel TDM stream to interface to external ADCs or DACs. Data is processed in twos complement, MSB first format. The left channel data field always precedes the right channel data field in 2-channel streams. In TDM mode, Slot 0 to Slot 3 are in the first half of the audio frame, and Slot 4 to Slot 7 are in the second half of the frame. The serial modes and the position of the data in the frame are set in Register R15 to Register R18 (serial port and converter control registers, Address 0x4015 to Address 0x4018).

The serial data clocks must be synchronous with the ADAU1761 master clock input. The LRCLK and BCLK pins are used to clock both the serial input and output ports. The ADAU1761 can be set as the master or the slave in a system. Because there is only one set of serial data clocks, the input and output ports must always be both master or both slave.

Register R15 and Register R16 (serial port control registers, Address 0x4015 and Address 0x4016) allow control of clock polarity and data input modes. The valid data formats are I<sup>2</sup>S, left-justified, right-justified (24-/20-/18-/16-bit), and TDM. In

all modes except for the right-justified modes, the serial port inputs an arbitrary number of bits up to a limit of 24. Extra bits do not cause an error, but they are truncated internally. The serial port can operate with an arbitrary number of BCLK transitions in each LRCLK frame. The LRCLK in TDM mode can be input to the ADAU1761 either as a 50% duty cycle clock or as a bit-wide pulse.

In TDM 8 mode, the ADAU1761 can be a master for  $f_s$  up to 48 kHz. Table 24 lists the modes in which the serial output port can function.

**Table 24. Serial Output Port Master/Slave Mode Capabilities**

$f_s$	2-Channel Modes (I <sup>2</sup> S, Left-Justified, Right-Justified)	8-Channel TDM
48 kHz	Master and slave	Master and slave
96 kHz	Master and slave	Slave

Table 25 describes the proper configurations for standard audio data formats.

**Table 25. Data Format Configurations**

Format	LRCLK Polarity (LRPOL)	LRCLK Mode (LRMOD)	BCLK Polarity (BPOL)	BCLK Cycles/Audio Frame (BPF[2:0])	Data Delay from LRCLK Edge (LRDEL[1:0])
I <sup>2</sup> S (see Figure 56)	Frame begins on falling edge	50% duty cycle	Data changes on falling edge	32 to 64	Delayed from LRCLK edge by 1 BCLK
Left-Justified (see Figure 57)	Frame begins on rising edge	50% duty cycle	Data changes on falling edge	32 to 64	Aligned with LRCLK edge
Right-Justified (see Figure 58)	Frame begins on rising edge	50% duty cycle	Data changes on falling edge	32 to 64	Delayed from LRCLK edge by 8, 12, or 16 BCLKs
TDM with Clock (see Figure 59)	Frame begins on falling edge	50% duty cycle	Data changes on falling edge	64 to 256	Delayed from start of word clock by 1 BCLK
TDM with Pulse (see Figure 60)	Frame begins on rising edge	Pulse	Data changes on falling edge	64 to 256	Delayed from start of word clock by 1 BCLK

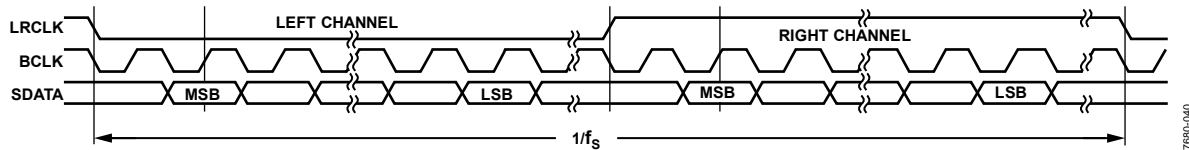

Figure 56. I<sup>2</sup>S Mode—16 Bits to 24 Bits per Channel

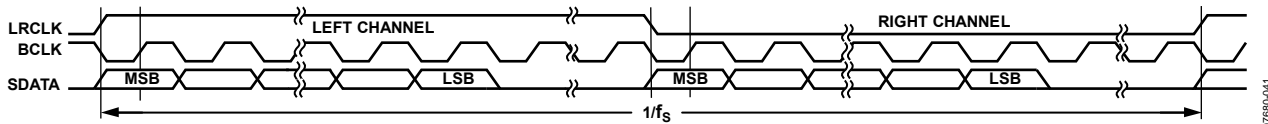

Figure 57. Left-Justified Mode—16 Bits to 24 Bits per Channel



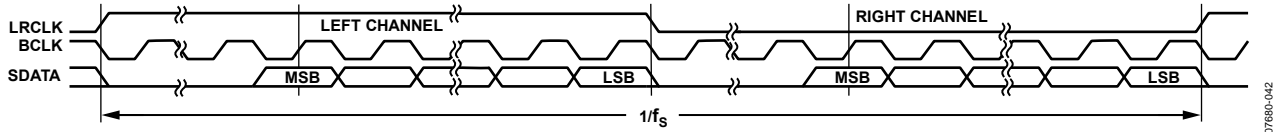

Figure 58. Right-Justified Mode—16 Bits to 24 Bits per Channel

07680-042

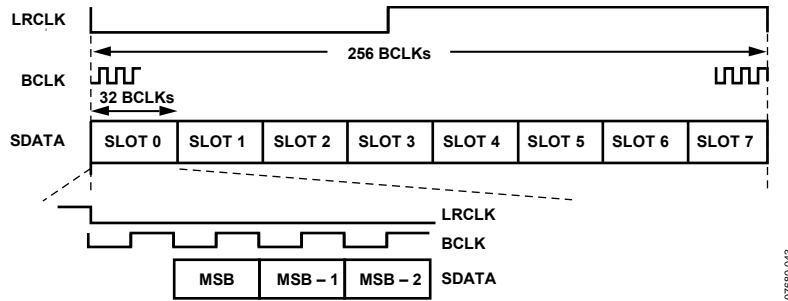

Figure 59. TDM 8 Mode

07680-043

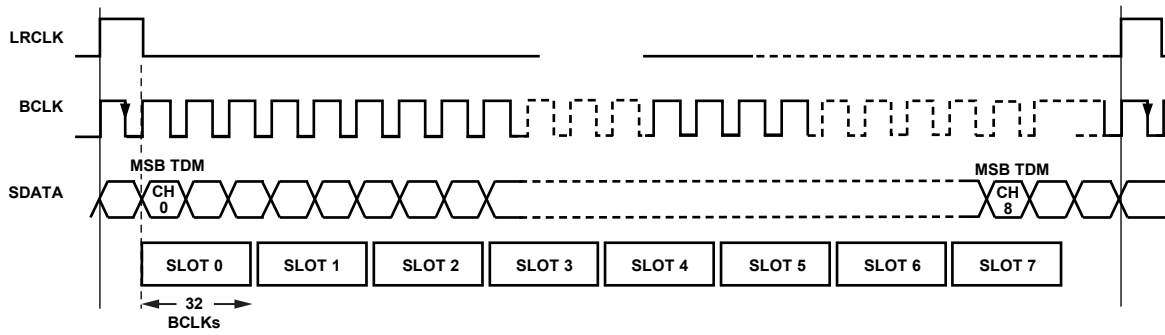

Figure 60. TDM 8 Mode with Pulse Word Clock

07680-044

## APPLICATIONS INFORMATION

### POWER SUPPLY BYPASS CAPACITORS

Each analog and digital power supply pin should be bypassed to its nearest appropriate ground pin with a single 100 nF capacitor. The connections to each side of the capacitor should be as short as possible, and the trace should stay on a single layer with no vias. For maximum effectiveness, locate the capacitor equidistant from the power and ground pins or, when equidistant placement is not possible, slightly closer to the power pin. Thermal connections to the ground planes should be made on the far side of the capacitor.

Each supply signal on the board should also be bypassed with a single bulk capacitor (10  $\mu$ F to 47  $\mu$ F).

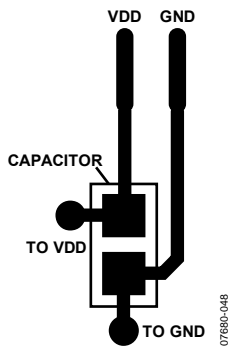

Figure 61. Recommended Power Supply Bypass Capacitor Layout

### GSM NOISE FILTER

In mobile phone applications, excessive 217 Hz GSM noise on the analog supply pins can degrade the audio quality. To avoid this problem, it is recommended that an L-C filter be used in series with the bypass capacitors for the AVDD pins. This filter should consist of a 1.2 nH inductor and a 9.1 pF capacitor in series between AVDD and ground, as shown in Figure 62.

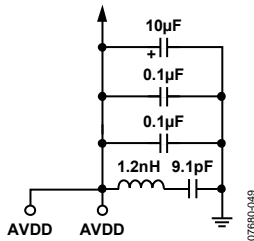

Figure 62. GSM Filter on the Analog Supply Pins

### GROUNDING

A single ground plane should be used in the application layout. Components in an analog signal path should be placed away from digital signals.

### EXPOSED PAD PCB DESIGN

The ADAU1761 has an exposed pad on the underside of the LFCSP. This pad is used to couple the package to the PCB for heat dissipation when using the outputs to drive earpiece or headphone loads. When designing a board for the ADAU1761, special consideration should be given to the following:

- A copper layer equal in size to the exposed pad should be on all layers of the board, from top to bottom, and should connect somewhere to a dedicated copper board layer (see Figure 63).
- Vias should be placed to connect all layers of copper, allowing for efficient heat and energy conductivity. For an example, see Figure 64, which has nine vias arranged in a 3 inch  $\times$  3 inch grid in the pad area.

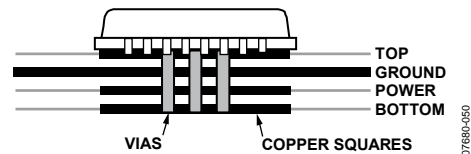

Figure 63. Exposed Pad Layout Example, Side View

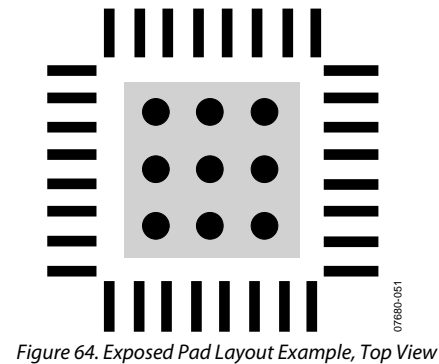

Figure 64. Exposed Pad Layout Example, Top View

## DSP CORE

### SIGNAL PROCESSING

The ADAU1761 is designed to provide all audio signal processing functions commonly used in stereo or mono low power record and playback systems. The signal processing flow is designed using the SigmaStudio software, which allows graphical entry and real-time control of all signal processing functions.

Many of the signal processing functions are coded using full, 56-bit, double-precision arithmetic data. The input and output word lengths of the DSP core are 24 bits. Four extra headroom bits are used in the processor to allow internal gains of up to 24 dB without clipping. Additional gains can be achieved by initially scaling down the input signal in the DSP signal flow.

### ARCHITECTURE

The DSP core consists of a simple 28-/56-bit multiply-accumulate unit (MAC) with two sources: a data source and a coefficient source. The data source can come from the data RAM, a ROM table of commonly used constant values, or the audio inputs to the core. The coefficient source can come from the parameter RAM, a ROM table of commonly used constant values, or the audio inputs to the core.

The two sources are multiplied in a 28-bit fixed-point multiplier and then the signal is input to the 56-bit adder; the result is usually stored in one of three 56-bit accumulator registers. The accumulators can be output from the core (in 28-bit format) or can optionally be written back into the data or parameter RAMs.

### PROGRAM COUNTER

The execution of instructions in the core is governed by a program counter, which sequentially steps through the addresses of the program RAM. The program counter starts every time a new audio frame is clocked into the core. SigmaStudio inserts a jump-to-start command at the end of every program. The program counter increments sequentially until reaching this command, and then jumps to the program start address and waits for the next audio frame to clock into the core.

### FEATURES

The SigmaDSP core was designed specifically for audio processing and therefore includes several features intended for maximizing efficiency. These include hardware decibel conversion and audio-specific ROM constants.

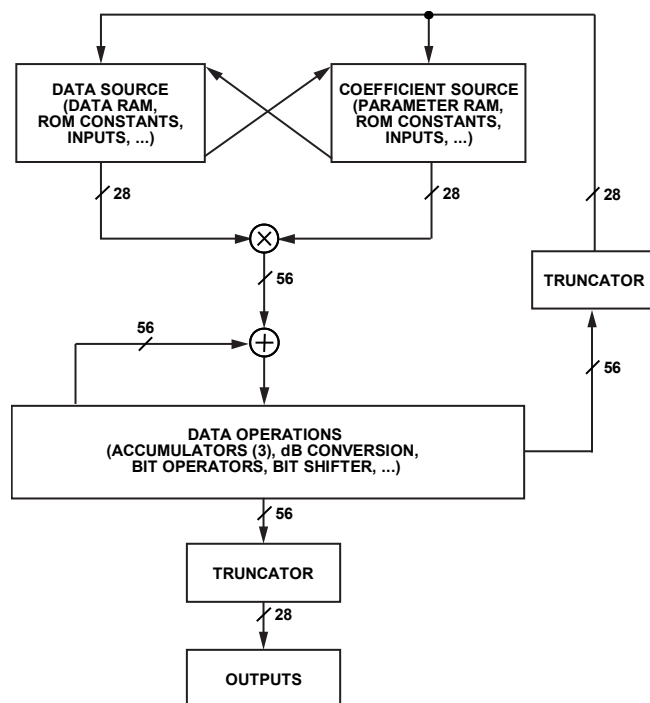

Figure 65. Simplified DSP Core Architecture

07650-067

# ADAU1761

## NUMERIC FORMATS

DSP systems commonly use a standard numeric format. Fractional number systems are specified by an A.B format, where A is the number of bits to the left of the decimal point and B is the number of bits to the right of the decimal point.

The ADAU1761 uses numerical format 5.23 for both the parameter and data values.

### Numerical Format: 5.23

Linear range:  $-16.0$  to  $(+16.0 - 1 \text{ LSB})$

Examples:

- 1000 0000 0000 0000 0000 0000 =  $-16.0$
- 1110 0000 0000 0000 0000 0000 =  $-4.0$
- 1111 1000 0000 0000 0000 0000 =  $-1.0$
- 1111 1110 0000 0000 0000 0000 =  $-0.25$
- 1111 1111 0011 0011 0011 0011 =  $-0.1$
- 1111 1111 1111 1111 1111 1111 = (1 LSB below 0)
- 0000 0000 0000 0000 0000 0000 = 0
- 0000 0000 1100 1100 1100 1101 = 0.1
- 0000 0010 0000 0000 0000 0000 = 0.25
- 0000 1000 0000 0000 0000 0000 = 1.0
- 0010 0000 0000 0000 0000 0000 = 4.0
- 0111 1111 1111 1111 1111 1111 =  $(16.0 - 1 \text{ LSB})$

The serial port accepts up to 24 bits on the input and is sign-extended to the full 28 bits of the DSP core. This allows internal gains of up to 24 dB without internal clipping.

A digital clipper circuit is used between the output of the DSP core and the DACs or serial port outputs (see Figure 66). This circuit clips the top four bits of the signal to produce a 24-bit output with a range of 1.0 (minus 1 LSB) to  $-1.0$ . Figure 66 shows the maximum signal levels at each point in the data flow in both binary and decibel levels.

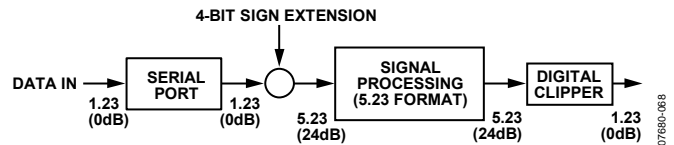

Figure 66. Numeric Precision and Clipping Structure

## PROGRAMMING

On power-up, the ADAU1761 must be set with a clocking scheme and then loaded with register settings. After the codec signal path is set up, the DSP core can be programmed. There are 1024 instruction cycles per audio sample, resulting in an internal clock rate of 49.152 MHz when  $f_s = 48 \text{ kHz}$ .

The part can be programmed easily using SigmaStudio (see Figure 67), a graphical tool provided by Analog Devices. No knowledge of writing line-level DSP code is required. More information about SigmaStudio can be found at [www.analog.com](http://www.analog.com).

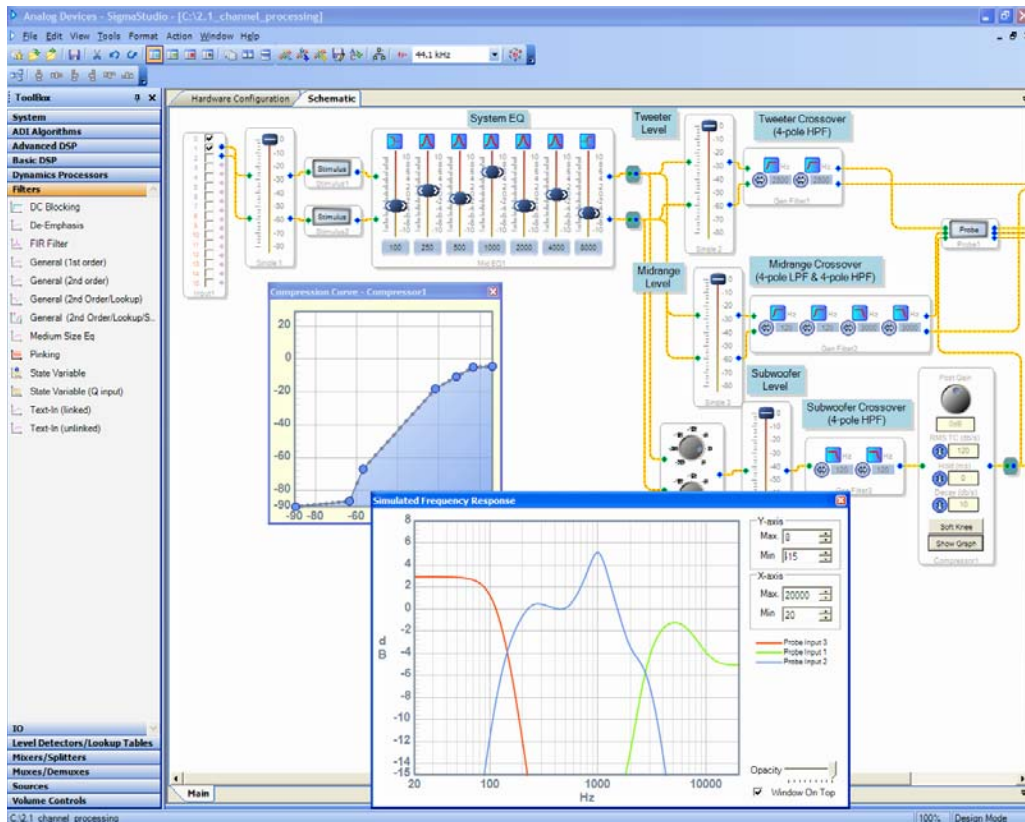

Figure 67. SigmaStudio Screen Shot

## PROGRAM RAM, PARAMETER RAM, AND DATA RAM

Table 26. RAM Map and Read/Write Modes

Memory	Size	Address Range	Read	Write	Write Modes
Parameter RAM	1024 × 32	0 to 1023 (0x0000 to 0x03FF)	Yes	Yes	Direct, safeload
Program RAM	1024 × 40	2048 to 3071 (0x0800 to 0x0BFF)	Yes	Yes	Direct

Table 26 shows the RAM map (the ADAU1761 register map is provided in the Control Registers section). The address space encompasses a set of registers and three RAMs: program, parameter, and data. The program RAM and parameter RAM are not initialized on power-up and are in an unknown state until written to.

### PROGRAM RAM

The program RAM contains the 40-bit operation codes that are executed by the core. The SigmaStudio compiler calculates maximum instructions per frame for a project and generates an error when the value exceeds the maximum allowable instructions per frame based on the sample rate of the signals in the core.

Because the end of a program contains a jump-to-start command, the unused program RAM space does not need to be filled with no-operation (NOP) commands.

### PARAMETER RAM

The parameter RAM is 32 bits wide and occupies Address 0 to Address 1023. Each parameter is padded with four 0s before the MSB to extend the 28-bit word to a full 4-byte width. The data format of the parameter RAM is twos complement, 5.23. This means that the coefficients can range from +16.0 (minus 1 LSB) to -16.0, with 1.0 represented by the binary word 0000 1000 0000 0000 0000 0000 0000 or by the hexadecimal word 0x00 0x80 0x00 0x00.

The parameter RAM can be written to directly or with a safe-load write. The direct write mode of operation is typically used during a complete new loading of the RAM using burst mode addressing to avoid any clicks or pops in the outputs. Note that this mode can be used during live program execution, but because there is no handshaking between the core and the control port, the parameter RAM is unavailable to the DSP core during control writes, resulting in clicks and pops in the audio stream.

SigmaStudio automatically assigns the first eight positions to safeload parameters; therefore, project-specific parameters start at Address 0x0008.

### DATA RAM

The ADAU1761 data RAM is used to store audio data-words for processing. The user cannot directly address this RAM space, which has a size of 4096 words, from the control port.

When implementing blocks, such as delays, that require large amounts of data RAM space, data RAM utilization should be taken into account. The SigmaDSP core processes delay times in one-sample increments; therefore, the total pool of delay available to the user equals 4096 multiplied by the sample period. For a  $f_{s,DSP}$  of 48 kHz, the pool of available delay is a maximum of about 86 ms, where  $f_{s,DSP}$  is the DSP core sampling rate. In practice, this much data memory is not available to the user because every block in a design uses a few data memory locations for its processing. In most DSP programs, this does not significantly affect the total delay time. The SigmaStudio compiler manages the data RAM and indicates whether the number of addresses needed in the design exceeds the maximum number available.

### READ/WRITE DATA FORMATS

The read/write formats of the control port are designed to be byte oriented to allow for easy programming of common microcontroller chips. To fit into a byte-oriented format, 0s are appended to the data fields before the MSB to extend the data-word to eight bits. For example, 28-bit words written to the parameter RAM are appended with four leading 0s to equal 32 bits (four bytes); 40-bit words written to the program RAM are not appended with 0s because they are already a full five bytes. These zero-padded data fields are appended to a 3-byte field consisting of a 7-bit chip address, a read/write bit, and a 16-bit RAM/register address. The control port knows how many data bytes to expect based on the address given in the first three bytes.

The total number of bytes for a single-location write command can vary from one byte (for a control register write) to five bytes (for a program RAM write). Burst mode can be used to fill contiguous register or RAM locations. A burst mode write begins by writing the address and data of the first RAM or register location to be written. Rather than ending the control port transaction (by issuing a stop command in I<sup>2</sup>C mode or by bringing the CLATCH signal high in SPI mode after the data-word), as would be done in a single-address write, the next data-word can be written immediately without specifying its address. The ADAU1761 control port autoincrements the address of each write even across the boundaries of the different RAMs and registers. Table 28 and Table 30 show examples of burst mode writes.

# ADAU1761

**Table 27. Parameter RAM Read/Write Format (Single Address)**

Byte 0	Byte 1	Byte 2	Byte 3	Bytes[4:6]
chip_adr[6:0], R/W	param_adr[15:8]	param_adr[7:0]	0000, param[27:24]	param[23:0]

**Table 28. Parameter RAM Block Read/Write Format (Burst Mode)**

Byte 0	Byte 1	Byte 2	Byte 3	Bytes[4:6]	Bytes[7:10]	Bytes[11:14]
chip_adr[6:0], R/W	param_adr[15:8]	param_adr[7:0]	0000, param[27:24]	param[23:0]		
			←param_adr→	param_adr + 1	param_adr + 2	

**Table 29. Program RAM Read/Write Format (Single Address)**

Byte 0	Byte 1	Byte 2	Bytes[3:7]
chip_adr[6:0], R/W	prog_adr[15:8]	prog_adr[7:0]	prog[39:0]

**Table 30. Program RAM Block Read/Write Format (Burst Mode)**

Byte 0	Byte 1	Byte 2	Bytes[3:7]	Bytes[8:12]	Bytes[13:17]
chip_adr[6:0], R/W	prog_adr[15:8]	prog_adr[7:0]	prog[39:0]		
			←prog_adr→	prog_adr + 1	prog_adr + 2

## SOFTWARE SAFELOAD

To update parameters in real time while avoiding pop and click noises on the output, the ADAU1761 uses a software safeload mechanism. The software safeload mechanism enables the SigmaDSP core to load new parameters into RAM while guaranteeing that the parameters are not in use. This prevents an undesirable condition where an instruction could execute with a mix of old and new parameters.

SigmaStudio sets up the necessary code and parameters automatically for new projects. The safeload code, along with other initialization code, fills the first 39 locations in program RAM. The first eight parameter RAM locations (Address 0x0000 to Address 0x0007) are configured by default in SigmaStudio as described in Table 31.

**Table 31. Software Safeload Parameter RAM Defaults**

Address (Hex)	Function
0x0000	Modulo RAM size
0x0001	Safeload Data 1
0x0002	Safeload Data 2
0x0003	Safeload Data 3
0x0004	Safeload Data 4
0x0005	Safeload Data 5
0x0006	Safeload target address (offset of -1)
0x0007	Number of words to write/safeload trigger

Address 0x0000, which controls the modulo RAM size, is set by SigmaStudio and is based on the dynamic address generator mode of the project.

Parameter RAM Address 0x0001 to Address 0x0005 are the five data slots for storing the data to be safeloaded. The safeload parameter space contains five data slots by default because most standard signal processing algorithms have five parameters or less.

Address 0x0006 is the target address in parameter RAM (with an offset of -1). This designates the first address to be written. If more than one word is written, the address increments automatically for each data-word. Up to five sequential parameter RAM locations can be updated with safeload during each audio frame. The target address offset of -1 is used because the write address is calculated relative to the address of the data, which starts at Address 0x0001. Therefore, to update a parameter at Address 0x000A, the target address is 0x0009.

Address 0x0007 designates the number of words to be written into the parameter RAM during the safeload. A biquad filter uses all five safeload data addresses. A simple mono gain cell uses only one safeload data address. Writing to this address also triggers the safeload write to occur in the next audio frame.

The safeload mechanism is software based and executes once per audio frame. Therefore, system designers must take care when designing the communication protocol. A delay equal to or greater than the sampling period (the inverse of sampling frequency) is required between each safeload write. A sample rate of 48 kHz equates to a delay of at least 21 μs. If this delay is not observed, the downloaded data is corrupted.

## SOFTWARE SLEW

When the values of signal processing parameters are changed abruptly in real time, they sometimes cause pop and click sounds to appear on the audio outputs. To avoid pops and clicks, some algorithms in SigmaStudio implement a software slew functionality. Algorithms using software slew set a target value for a parameter and continuously update the value of that parameter until it reaches the target.

The target value takes an additional space in parameter RAM, and the current value of the parameter is updated in the non-modulo section of data RAM. Assignment of parameters and non-modulo data RAM is handled by the SigmaStudio compiler and does not need to be programmed manually.

Slew parameters can follow several different curves, including an RC-type curve and a linear curve. These curve types are coded into each algorithm and cannot be modified by the user.

Because algorithms that use software slew generally require more RAM than their nonslew equivalents, they should be used only in situations where a parameter will change during operation of the device.

Figure 68 shows an example of volume slew applied to a sine wave.

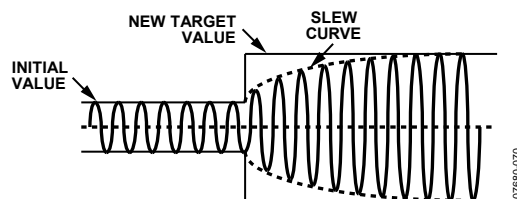

Figure 68. Example of Volume Slew

07680-070

## GENERAL-PURPOSE INPUT/OUTPUT

The serial data input/output pins (Pin 26 to Pin 29) are shared with the general-purpose input/output function. Each of these four pins can be set to only one of these functions. The function of these pins is set in the serial data/GPIO pin configuration register (Address 0x40F4).

The GPIOx pins can be used as inputs or outputs. These pins are readable and can be set through the control port or directly by the SigmaDSP core. When configured as inputs, the GPIOx pins can be used with push-button switches or rotary encoders to control DSP program settings. These pins can also be used with digital outputs to drive LEDs or external logic to indicate the status of internal signals and control other devices. Examples of this use include indicating signal overload, signal present, and button press confirmation.

When configured as an output, each GPIO pin can typically drive 2 mA, which is enough current to directly drive some high efficiency LEDs. Standard LEDs require about 20 mA of current and can be driven from a GPIO output with an external transistor or buffer. Because of issues that can arise from simultaneously driving or sinking a large amount of current on many pins, avoid connecting high efficiency LEDs directly to many or all of the GPIO pins when designing the application.

If many LEDs are required, use an external driver. When the GPIO pins are configured as open-collector outputs, they should be pulled up to a maximum voltage equal to the voltage set on IOVDD.

The configuration of the GPIO functions is set up in the GPIO pin control registers (Register R48 to Register R51, Address 0x40C6 to Address 0x40C9).

### GPIO PINS SET FROM THE CONTROL PORT

The GPIO pins can also be configured to be directly controlled from the I<sup>2</sup>C/SPI control port. When the pins are set to this mode, four memory locations are enabled for the GPIO pin settings. The physical settings on the GPIO pins mirror the settings of the LSB of these 4-byte-wide memory locations.

**Table 32. GPIOx Pin Memory Settings (Set from Control Port)**

Memory Location		Bits[31:1]	Bit 0
Decimal	Hex		
1568	0x0620	Reserved	GPIO0SET
1569	0x0621	Reserved	GPIO1SET
1570	0x0622	Reserved	GPIO2SET
1571	0x0623	Reserved	GPIO3SET



# CONTROL REGISTERS

Table 33. Register Map

Reg	Address	Name	Bit 7	Bit 6	Bit 5	Bit 4	Bit 3	Bit 2	Bit 1	Bit 0	Default	
R0	0x4000	Clock control	Reserved				CLKSRC	INFREQ[1:0]		COREN	00000000	
R1	0x4002	PLL control	M[15:8]								00000000	
			M[7:0]								11111101	
			N[15:8]								00000000	
			N[7:0]								00001100	
			Reserved	R[3:0]			X[1:0]		Type	00010000		
Reserved			Lock		PLLEN	00000000						
R2	0x4008	Dig mic/jack detect	Jddb[1:0]		JDFUNC[1:0]	JDMUTE	Reserved		JDPOL	00000000		
R3	0x4009	Rec power mgmt	Reserved	MXBIAS[1:0]		ADCBIAS[1:0]		RBIAS[1:0]		Reserved	00000000	
R4	0x400A	Rec Mixer Left 0	Reserved	LINPG[2:0]			LINNG[2:0]			MX1EN	00000000	
R5	0x400B	Rec Mixer Left 1	Reserved			LDBOOST[1:0]		MX1AUXG[2:0]			00000000	
R6	0x400C	Rec Mixer Right 0	Reserved	RINPG[2:0]			RINNG[2:0]			MX2EN	00000000	
R7	0x400D	Rec Mixer Right 1	Reserved			RDBOOST[1:0]		MX2AUXG[2:0]			00000000	
R8	0x400E	Left diff input vol	LDVOL[5:0]						LDMUTE	LDEN	00000000	
R9	0x400F	Right diff input vol	RDVOL[5:0]						RDMUTE	RDEN	00000000	
R10	0x4010	Record mic bias	Reserved				MPERF	MBI	Reserved		MBIEN	00000000
R11	0x4011	ALC 0	PGASLEW[1:0]		ALCMAX[2:0]			ALCSEL[2:0]			00000000	
R12	0x4012	ALC 1	ALCHOLD[3:0]				ALCTARG[3:0]				00000000	
R13	0x4013	ALC 2	ALCATCK[3:0]				ALCDEC[3:0]				00000000	
R14	0x4014	ALC 3	NGTYP[1:0]		NGEN		NGTHR[4:0]				00000000	
R15	0x4015	Serial Port 0	DITHEN	Reserved	LRMOD	BPOL	LRPOL	CHPF[1:0]		MS	00000000	
R16	0x4016	Serial Port 1	BPF[2:0]			ADTDM	DATDM	MSBP	LRDEL[1:0]			00000000
R17	0x4017	Converter 0	Reserved	DAPAIR[1:0]		DAOSR	ADOSR	CONVSR[2:0]				00000000
R18	0x4018	Converter 1	Reserved		DAMUTE[1:0]		ADMUTE[1:0]		ADPAIR[1:0]			00000000
R19	0x4019	ADC control	Reserved	ADCPOL	HPF	DMPOL	DMSW	INSEL	ADCEN[1:0]			00010000
R20	0x401A	Left digital vol	LADVOL[7:0]								00000000	
R21	0x401B	Right digital vol	RADVOL[7:0]								00000000	
R22	0x401C	Play Mixer Left 0	Reserved	MX3RM	MX3LM	MX3AUXG[3:0]				MX3EN	00000000	
R23	0x401D	Play Mixer Left 1	MX3G2[3:0]				MX3G1[3:0]				00000000	
R24	0x401E	Play Mixer Right 0	Reserved	MX4RM	MX4LM	MX4AUXG[3:0]				MX4EN	00000000	
R25	0x401F	Play Mixer Right 1	MX4G2[3:0]				MX4G1[3:0]				00000000	
R26	0x4020	Play L/R mixer left	Reserved			MX5G4[1:0]		MX5G3[1:0]		MX5EN	00000000	
R27	0x4021	Play L/R mixer right	Reserved			MX6G3[1:0]		MX6G4[1:0]		MX6EN	00000000	
R28	0x4022	Play L/R mixer mono	Reserved					MX7[1:0]		MX7EN	00000000	
R29	0x4023	Play HP left vol	LHPVOL[5:0]						LHPM	HPDUAL	00000010	
R30	0x4024	Play HP right vol	RHPVOL[5:0]						RHPM	HPMODE	00000010	
R31	0x4025	Line output left vol	LOUTVOL[5:0]						LOUTM	LOMODE	00000010	
R32	0x4026	Line output right vol	ROUTVOL[5:0]						ROUTM	ROMODE	00000010	
R33	0x4027	Play mono output	MONOVOL[5:0]						MONOM	MOMODE	00000010	
R34	0x4028	Pop/click suppress	Reserved			POPMODE	Popless	ASLEW[1:0]		Reserved	00000000	
R35	0x4029	Play power mgmt	HPBIAS[1:0]		DACBIAS[1:0]		PBIAS[1:0]		PREN	PLEN	00000000	
R36	0x402A	DAC Control 0	DACMONO[1:0]		DACPOL	Reserved		DEMPH	DACEN[1:0]		00000000	
R37	0x402B	DAC Control 1	LDAVOL[7:0]								00000000	
R38	0x402C	DAC Control 2	RDAVOL[7:0]								00000000	
R39	0x402D	Serial port pad	ADCSDP[1:0]		DACSDP[1:0]		LRCLKP[1:0]		BCLKP[1:0]		10101010	
R40	0x402F	Control Port Pad 0	CDATP[1:0]		CLCHP[1:0]		SCLP[1:0]		SDAP[1:0]		10101010	
R41	0x4030	Control Port Pad 1	Reserved								SDASTR	00000000
R42	0x4031	Jack detect pin	Reserved		JDSTR	Reserved	JDP[1:0]		Reserved		00001000	
R43	0x40C0	Cyclic redundancy check	CRC[31:24]								00000000	
R44	0x40C1		CRC[23:16]								00000000	
R45	0x40C2		CRC[15:8]								00000000	
R46	0x40C3		CRC[7:0]								00000000	

# ADAU1761

Reg	Address	Name	Bit 7	Bit 6	Bit 5	Bit 4	Bit 3	Bit 2	Bit 1	Bit 0	Default	
R47	0x40C4	CRC enable	Reserved							CRCEN	00000000	
R48	0x40C6	GPIO0 pin control	Reserved				GPIO0[3:0]				00000000	
R49	0x40C7	GPIO1 pin control	Reserved				GPIO1[3:0]				00000000	
R50	0x40C8	GPIO2 pin control	Reserved				GPIO2[3:0]				00000000	
R51	0x40C9	GPIO3 pin control	Reserved				GPIO3[3:0]				00000000	
R52	0x40D0	Watchdog enable	Reserved							DOGEN	00000000	
R53	0x40D1	Watchdog value	DOG[23:16]									00000000
R54	0x40D2		DOG[15:8]									00000000
R55	0x40D3		DOG[7:0]									00000000
R56	0x40D4	Watchdog error	Reserved							DOGER	00000000	
R57	0x40EB	DSP sampling rate setting	Reserved					DSPSR[2:0]			00000001	
R58	0x40F2	Serial input route control	Reserved				SINRT[3:0]				00000000	
R59	0x40F3	Serial output route control	Reserved				SOUTRT[3:0]				00000000	
R60	0x40F4	Serial data/GPIO pin configuration	Reserved				LRGP3	BGP2	SDOGP1	SDIGP0	00000000	
R61	0x40F5	DSP enable	Reserved							DSPEN	00000000	
R62	0x40F6	DSP run	Reserved							DSPRUN	00000000	
R63	0x40F7	DSP slew modes	Reserved			MOSLW	ROSLW	LOSLW	RHPSLW	LHPSLW	00000000	
R64	0x40F8	Serial port sampling rate	Reserved					SPSR[2:0]			00000000	
R65	0x40F9	Clock Enable 0	Reserved	SLEWPD	ALCPD	DECPD	SOUTPD	INTPD	SINPD	SPPD	00000000	
R66	0x40FA	Clock Enable 1	Reserved						CLK0	CLK1	00000000	

## CONTROL REGISTER DETAILS

All registers except for the PLL control register are 1-byte write and read registers.

### R0: Clock Control 16384 (0x4000)

Bit 7	Bit 6	Bit 5	Bit 4	Bit 3	Bit 2	Bit 1	Bit 0
Reserved				CLKSRC	INFREQ[1:0]		COREN

Table 34. Clock Control Register

Bit	Bit Name	Description										
3	CLKSRC	Clock source select. 0 = direct from MCLK pin (default). 1 = PLL clock.										
[2:1]	INFREQ[1:0]	Input clock frequency. Sets the core clock rate that generates the core clock. If the PLL is used, this value is automatically set to $1024 \times f_s$ .										
		<table border="1"> <thead> <tr> <th>Setting</th> <th>Input Clock Frequency</th> </tr> </thead> <tbody> <tr> <td>00</td> <td><math>256 \times f_s</math> (default)</td> </tr> <tr> <td>01</td> <td><math>512 \times f_s</math></td> </tr> <tr> <td>10</td> <td><math>768 \times f_s</math></td> </tr> <tr> <td>11</td> <td><math>1024 \times f_s</math></td> </tr> </tbody> </table>	Setting	Input Clock Frequency	00	$256 \times f_s$ (default)	01	$512 \times f_s$	10	$768 \times f_s$	11	$1024 \times f_s$
Setting	Input Clock Frequency											
00	$256 \times f_s$ (default)											
01	$512 \times f_s$											
10	$768 \times f_s$											
11	$1024 \times f_s$											
0	COREN	Core clock enable. Only the R0 and R1 registers can be accessed when this bit is set to 0 (core clock disabled). 0 = core clock disabled (default). 1 = core clock enabled.										

**R1: PLL Control 16386 (0x4002)**

Byte	Bit 7	Bit 6	Bit 5	Bit 4	Bit 3	Bit 2	Bit 1	Bit 0
0					M[15:8]			
1					M[7:0]			
2					N[15:8]			
3					N[7:0]			
4	Reserved		R[3:0]			X[1:0]		Type
5			Reserved				Lock	PLLEN

**Table 35. PLL Control Register**

Byte	Bit	Bit Name	Description																		
0	[7:0]	M[15:8]	PLL denominator MSB. This value is concatenated with M[7:0] to make up a 16-bit number.																		
1	[7:0]	M[7:0]	PLL denominator LSB. This value is concatenated with M[15:8] to make up a 16-bit number.																		
			<table border="1"> <thead> <tr> <th>M[15:8] (MSB)</th> <th>M[7:0] (LSB)</th> <th>Value of M</th> </tr> </thead> <tbody> <tr> <td>00000000</td> <td>00000000</td> <td>0</td> </tr> <tr> <td>...</td> <td>...</td> <td>...</td> </tr> <tr> <td>00000000</td> <td>11111101</td> <td>253 (default)</td> </tr> <tr> <td>...</td> <td>...</td> <td>...</td> </tr> <tr> <td>11111111</td> <td>11111111</td> <td>65,535</td> </tr> </tbody> </table>	M[15:8] (MSB)	M[7:0] (LSB)	Value of M	00000000	00000000	0	...	...	...	00000000	11111101	253 (default)	...	...	...	11111111	11111111	65,535
M[15:8] (MSB)	M[7:0] (LSB)	Value of M																			
00000000	00000000	0																			
...	...	...																			
00000000	11111101	253 (default)																			
...	...	...																			
11111111	11111111	65,535																			
2	[7:0]	N[15:8]	PLL numerator MSB. This value is concatenated with N[7:0] to make up a 16-bit number.																		
3	[7:0]	N[7:0]	PLL numerator LSB. This value is concatenated with N[15:8] to make up a 16-bit number.																		
			<table border="1"> <thead> <tr> <th>N[15:8] (MSB)</th> <th>N[7:0] (LSB)</th> <th>Value of N</th> </tr> </thead> <tbody> <tr> <td>00000000</td> <td>00000000</td> <td>0</td> </tr> <tr> <td>...</td> <td>...</td> <td>...</td> </tr> <tr> <td>00000000</td> <td>00001100</td> <td>12 (default)</td> </tr> <tr> <td>...</td> <td>...</td> <td>...</td> </tr> <tr> <td>11111111</td> <td>11111111</td> <td>65,535</td> </tr> </tbody> </table>	N[15:8] (MSB)	N[7:0] (LSB)	Value of N	00000000	00000000	0	...	...	...	00000000	00001100	12 (default)	...	...	...	11111111	11111111	65,535
N[15:8] (MSB)	N[7:0] (LSB)	Value of N																			
00000000	00000000	0																			
...	...	...																			
00000000	00001100	12 (default)																			
...	...	...																			
11111111	11111111	65,535																			
4	[6:3]	R[3:0]	PLL integer setting.																		
			<table border="1"> <thead> <tr> <th>Setting</th> <th>Value of R</th> </tr> </thead> <tbody> <tr> <td>0010</td> <td>2 (default)</td> </tr> <tr> <td>0011</td> <td>3</td> </tr> <tr> <td>0100</td> <td>4</td> </tr> <tr> <td>0101</td> <td>5</td> </tr> <tr> <td>0110</td> <td>6</td> </tr> <tr> <td>0111</td> <td>7</td> </tr> <tr> <td>1000</td> <td>8</td> </tr> </tbody> </table>	Setting	Value of R	0010	2 (default)	0011	3	0100	4	0101	5	0110	6	0111	7	1000	8		
Setting	Value of R																				
0010	2 (default)																				
0011	3																				
0100	4																				
0101	5																				
0110	6																				
0111	7																				
1000	8																				
4	[2:1]	X[1:0]	PLL input clock divider.																		
			<table border="1"> <thead> <tr> <th>Setting</th> <th>Value of X</th> </tr> </thead> <tbody> <tr> <td>00</td> <td>1 (default)</td> </tr> <tr> <td>01</td> <td>2</td> </tr> <tr> <td>10</td> <td>3</td> </tr> <tr> <td>11</td> <td>4</td> </tr> </tbody> </table>	Setting	Value of X	00	1 (default)	01	2	10	3	11	4								
Setting	Value of X																				
00	1 (default)																				
01	2																				
10	3																				
11	4																				
4	0	Type	Type of PLL. When set to integer mode, the values of M and N are ignored. 0 = integer (default). 1 = fractional.																		
5	1	Lock	PLL lock. This read-only bit is flagged when the PLL has finished locking. 0 = PLL unlocked (default). 1 = PLL locked.																		
5	0	PLLEN	PLL enable. 0 = PLL disabled (default). 1 = PLL enabled.																		

# ADAU1761

## R2: Digital Microphone/Jack Detection Control 16392 (0x4008)

Bit 7	Bit 6	Bit 5	Bit 4	Bit 3	Bit 2	Bit 1	Bit 0
JDDB[1:0]		JDFUNC[1:0]		JDMUTE	Reserved		JDPOL

Table 36. Digital Microphone/Jack Detection Control Register

Bit	Bit Name	Description	
[7:6]	JDDB[1:0]	Jack detect debounce time.	
		<b>Setting</b>	<b>Debounce Time</b>
		00	5 ms (default)
		01	10 ms
		10	20 ms
	11	40 ms	
[5:4]	JDFUNC[1:0]	JACKDET/MICIN pin function. Enables or disables the jack detect function or configures the pin for a digital microphone input.	
		<b>Setting</b>	<b>Pin Function</b>
		00	Jack detect off (default)
		01	Jack detect on
		10	Digital microphone input
	11	Reserved	
3	JDMUTE	When enabled, this bit mutes the line outputs when a jack input is detected. JDFUNC[1:0] must be set to 01. 0 = mute disabled (default). 1 = mute enabled.	
0	JDPOL	Jack detect polarity. Detects high or low signal. 0 = detect high signal (default). 1 = detect low signal.	

**R3: Record Power Management 16393 (0x4009)**

This register manages the power consumption for the record path. In particular, the current distribution for the mixer boosts, ADCs, record path mixers, and PGAs can be set in one of four modes. These settings are normal operation, power saving mode, enhanced performance mode, and extreme power saving mode. Each of these modes draws current from a central bias. Enhanced performance mode offers the highest performance with the trade-off of higher power consumption.

Bit 7	Bit 6	Bit 5	Bit 4	Bit 3	Bit 2	Bit 1	Bit 0
Reserved	MXBIAS[1:0]		ADCBIAS[1:0]		RBIAS[1:0]		Reserved

**Table 37. Record Power Management Register**

Bit	Bit Name	Description
[6:5]	MXBIAS[1:0]	Mixer amp bias boost. Sets the boost level for the bias current of the record path mixers. In some cases, the boost level enhances the THD + N performance.
		<b>Setting</b>
		<b>Boost Level</b>
		00
		01
[4:3]	ADCBIAS[1:0]	ADC bias control. Sets the bias current for the ADCs based on the mode of operation selected.
		<b>Setting</b>
		<b>ADC Bias Control</b>
		00
		01
[2:1]	RBIAS[1:0]	Record path bias control. Sets the bias current for the PGAs and mixers in the record path.
		<b>Setting</b>
		<b>Record Path Bias Control</b>
		00
		01
		10
		11

# ADAU1761

## R4: Record Mixer Left (Mixer 1) Control 0 16394 (0x400A)

This register controls the gain of single-ended inputs for the left channel record path. The left channel record mixer is referred to as Mixer 1.

Bit 7	Bit 6	Bit 5	Bit 4	Bit 3	Bit 2	Bit 1	Bit 0
Reserved	LINPG[2:0]			LINNG[2:0]			MX1EN

**Table 38. Record Mixer Left (Mixer 1) Control 0 Register**

Bit	Bit Name	Description	
[6:4]	LINPG[2:0]	Gain for a left channel single-ended input from the LINP pin, input to Mixer 1.	
		<b>Setting</b>	<b>Gain</b>
		000	Mute (default)
		001	-12 dB
		010	-9 dB
		011	-6 dB
		100	-3 dB
		101	0 dB
		110	3 dB
		111	6 dB
[3:1]	LINNG[2:0]	Gain for a left channel single-ended input from the LINN pin, input to Mixer 1.	
		<b>Setting</b>	<b>Gain</b>
		000	Mute (default)
		001	-12 dB
		010	-9 dB
		011	-6 dB
		100	-3 dB
		101	0 dB
		110	3 dB
		111	6 dB
0	MX1EN	Left channel mixer enable in the record path. Referred to as Mixer 1. 0 = mixer disabled (default). 1 = mixer enabled.	

**R5: Record Mixer Left (Mixer 1) Control 1 16395 (0x400B)**

This register controls the boost gain of the left channel differential PGA input and the gain for the left channel auxiliary input in the record path. The left channel record mixer is referred to as Mixer 1.

Bit 7	Bit 6	Bit 5	Bit 4	Bit 3	Bit 2	Bit 1	Bit 0
Reserved			LDBOOST[1:0]		MX1AUXG[2:0]		

**Table 39. Record Mixer Left (Mixer 1) Control 1 Register**

Bit	Bit Name	Description	
[4:3]	LDBOOST[1:0]	Left channel differential PGA input gain boost, input to Mixer 1. The left differential input uses the LINP (positive signal) and LINN (negative signal) pins.	
		<b>Setting</b>	<b>Gain Boost</b>
		00	Mute (default)
		01	0 dB
		10	20 dB
	11	Reserved	
[2:0]	MX1AUXG[2:0]	Left single-ended auxiliary input gain from the LAUX pin in the record path, input to Mixer 1.	
		<b>Setting</b>	<b>Auxiliary Input Gain</b>
		000	Mute (default)
		001	-12 dB
		010	-9 dB
		011	-6 dB
		100	-3 dB
		101	0 dB
		110	3 dB
		111	6 dB

# ADAU1761

## R6: Record Mixer Right (Mixer 2) Control 0 16396 (0x400C)

This register controls the gain of single-ended inputs for the right channel record path. The right channel record mixer is referred to as Mixer 2.

Bit 7	Bit 6	Bit 5	Bit 4	Bit 3	Bit 2	Bit 1	Bit 0
Reserved	RINPG[2:0]			RINNG[2:0]			MX2EN

**Table 40. Record Mixer Right (Mixer 2) Control 0 Register**

Bit	Bit Name	Description	
[6:4]	RINPG[2:0]	Gain for a right channel single-ended input from the RINP pin, input to Mixer 2.	
		<b>Setting</b>	<b>Gain</b>
		000	Mute (default)
		001	-12 dB
		010	-9 dB
		011	-6 dB
		100	-3 dB
		101	0 dB
		110	3 dB
		111	6 dB
[3:1]	RINNG[2:0]	Gain for a right channel single-ended input from the RINN pin, input to Mixer 2.	
		<b>Setting</b>	<b>Gain</b>
		000	Mute (default)
		001	-12 dB
		010	-9 dB
		011	-6 dB
		100	-3 dB
		101	0 dB
		110	3 dB
		111	6 dB
0	MX2EN	Right channel mixer enable in the record path. Referred to as Mixer 2. 0 = mixer disabled (default). 1 = mixer enabled.	



**R7: Record Mixer Right (Mixer 2) Control 1 16397 (0x400D)**

This register controls the boost gain of the right channel differential PGA input and the gain for the right channel auxiliary input in the record path. The right channel record mixer is referred to as Mixer 2.

Bit 7	Bit 6	Bit 5	Bit 4	Bit 3	Bit 2	Bit 1	Bit 0
Reserved			RDBOOST[1:0]		MX2AUXG[2:0]		

**Table 41. Record Mixer Right (Mixer 2) Control 1 Register**

Bit	Bit Name	Description	
[4:3]	RDBOOST[1:0]	Right channel differential PGA input gain boost, input to Mixer 2. The right differential input uses the RINP (positive signal) and RINN (negative signal) pins.	
		<b>Setting</b>	<b>Gain Boost</b>
		00	Mute (default)
		01	0 dB
		10	20 dB
		11	Reserved
[2:0]	MX2AUXG[2:0]	Right single-ended auxiliary input gain from the RAUX pin in the record path, input to Mixer 2.	
		<b>Setting</b>	<b>Auxiliary Input Gain</b>
		000	Mute (default)
		001	-12 dB
		010	-9 dB
		011	-6 dB
		100	-3 dB
		101	0 dB
		110	3 dB
		111	6 dB

**R8: Left Differential Input Volume Control 16398 (0x400E)**

This register enables the differential path and sets the volume control for the left differential PGA input.

Bit 7	Bit 6	Bit 5	Bit 4	Bit 3	Bit 2	Bit 1	Bit 0
LDVOL[5:0]						LDMUTE	LDEN

**Table 42. Left Differential Input Volume Control Register**

Bit	Bit Name	Description	
[7:2]	LDVOL[5:0]	Left channel differential PGA input volume control. The left differential input uses the LINP (positive signal) and LINN (negative signal) pins. Each step corresponds to a 0.75 dB increase in gain. See Table 91 for a complete list of the volume settings.	
		<b>Setting</b>	<b>Volume</b>
		000000	-12 dB (default)
		000001	-11.25 dB
		...	...
		010000	0 dB
		...	...
		111110	34.5 dB
		111111	35.25 dB
		1	LDMUTE
0	LDEN	Left differential PGA enable. When enabled, the LINP and LINN pins are used as a full differential pair. When disabled, these two pins are configured as two single-ended inputs. 0 = enabled (default). 1 = disabled.	

# ADAU1761

## R9: Right Differential Input Volume Control 16399 (0x400F)

This register enables the differential path and sets the volume control for the right differential PGA input.

Bit 7	Bit 6	Bit 5	Bit 4	Bit 3	Bit 2	Bit 1	Bit 0
RDVOL[5:0]						RDMUTE	RDEN

Table 43. Right Differential Input Volume Control Register

Bit	Bit Name	Description																
[7:2]	RDVOL[5:0]	Right channel differential PGA input volume control. The right differential input uses the RINP (positive signal) and RINN (negative signal) pins. Each step corresponds to a 0.75 dB increase in gain. See Table 91 for a complete list of the volume settings. <table border="1" style="width: 100%; margin-top: 5px;"> <thead> <tr> <th>Setting</th> <th>Volume</th> </tr> </thead> <tbody> <tr> <td>000000</td> <td>-12 dB (default)</td> </tr> <tr> <td>000001</td> <td>-11.25 dB</td> </tr> <tr> <td>...</td> <td>...</td> </tr> <tr> <td>010000</td> <td>0 dB</td> </tr> <tr> <td>...</td> <td>...</td> </tr> <tr> <td>111110</td> <td>34.5 dB</td> </tr> <tr> <td>111111</td> <td>35.25 dB</td> </tr> </tbody> </table>	Setting	Volume	000000	-12 dB (default)	000001	-11.25 dB	...	...	010000	0 dB	...	...	111110	34.5 dB	111111	35.25 dB
Setting	Volume																	
000000	-12 dB (default)																	
000001	-11.25 dB																	
...	...																	
010000	0 dB																	
...	...																	
111110	34.5 dB																	
111111	35.25 dB																	
1	RDMUTE	Right differential input mute control. 0 = mute (default). 1 = unmute.																
0	RDEN	Right differential PGA enable. When enabled, the RINP and RINN pins are used as a full differential pair. When disabled, these two pins are configured as two single-ended inputs. 0 = enabled (default). 1 = disabled.																

## R10: Record Microphone Bias Control 16400 (0x4010)

This register controls the MICBIAS pin settings for biasing electret type analog microphones.

Bit 7	Bit 6	Bit 5	Bit 4	Bit 3	Bit 2	Bit 1	Bit 0
Reserved				MPERF	MBI	Reserved	MBIEN

Table 44. Record Microphone Bias Control Register

Bit	Bit Name	Description
3	MPERF	Microphone bias is enabled for high performance or normal operation. High performance operation sources more current to the microphone. 0 = normal operation (default). 1 = high performance.
2	MBI	Microphone voltage bias as a fraction of AVDD. 0 = $0.90 \times AVDD$ (default). 1 = $0.65 \times AVDD$ .
0	MBIEN	Enables the MICBIAS output. 0 = disabled (default). 1 = enabled.

**R11: ALC Control 0 16401 (0x4011)**

<b>Bit 7</b>	<b>Bit 6</b>	<b>Bit 5</b>	<b>Bit 4</b>	<b>Bit 3</b>	<b>Bit 2</b>	<b>Bit 1</b>	<b>Bit 0</b>
PGASLEW[1:0]		ALCMAX[2:0]			ALCSEL[2:0]		

**Table 45. ALC Control 0 Register**

Bit	Bit Name	Description	
[7:6]	PGASLEW[1:0]	PGA volume slew time when the ALC is off. The slew time is the period of time that a volume increase or decrease takes to ramp up or ramp down to the target volume set in Register R8 (left differential input volume control) and Register R9 (right differential input volume control).	
		<b>Setting</b>	<b>Slew Time</b>
		00	24 ms (default)
		01	48 ms
		10 11	96 ms Off
[5:3]	ALCMAX[2:0]	The maximum ALC gain sets a limit to the amount of gain that the ALC can provide to the input signal. This protects small signals from excessive amplification.	
		<b>Setting</b>	<b>Maximum ALC Gain</b>
		000	-12 dB (default)
		001	-6 dB
		010	0 dB
		011	6 dB
		100	12 dB
		101	18 dB
		110 111	24 dB 30 dB
[2:0]	ALCSEL[2:0]	ALC select. These bits set the channels that are controlled by the ALC. When set to right only, the ALC responds only to the right channel input and controls the gain of the right PGA amplifier only. When set to left only, the ALC responds only to the left channel input and controls the gain of the left PGA amplifier only. When set to stereo, the ALC responds to the greater of the left or right channel and controls the gain of both the left and right PGA amplifiers. DSP control allows the PGA gain to be set within the DSP or from external GPIO inputs. These bits must be off if manual control of the volume is desired.	
		<b>Setting</b>	<b>Channels</b>
		000	Off (default)
		001	Right only
		010	Left only
		011	Stereo
		100	DSP control
		101	Reserved
		110 111	Reserved Reserved

# ADAU1761

## R12: ALC Control 1 16402 (0x4012)

Bit 7	Bit 6	Bit 5	Bit 4	Bit 3	Bit 2	Bit 1	Bit 0
ALCHOLD[3:0]				ALCTARG[3:0]			

Table 46. ALC Control 1 Register

Bit	Bit Name	Description																																		
[7:4]	ALCHOLD[3:0]	ALC hold time. The ALC hold time is the amount of time that the ALC waits after a decrease in input level before increasing the gain to achieve the target level. The recommended minimum setting is 21 ms (0011) to prevent distortion on low frequency signals. The hold time doubles with every 1-bit increase.																																		
		<table border="1"> <thead> <tr> <th>Setting</th> <th>Hold Time</th> </tr> </thead> <tbody> <tr><td>0000</td><td>2.67 ms (default)</td></tr> <tr><td>0001</td><td>5.34 ms</td></tr> <tr><td>0010</td><td>10.68 ms</td></tr> <tr><td>0011</td><td>21.36 ms</td></tr> <tr><td>0100</td><td>42.72 ms</td></tr> <tr><td>0101</td><td>85.44 ms</td></tr> <tr><td>0110</td><td>170.88 ms</td></tr> <tr><td>0111</td><td>341.76 ms</td></tr> <tr><td>1000</td><td>683.52 ms</td></tr> <tr><td>1001</td><td>1.367 sec</td></tr> <tr><td>1010</td><td>2.7341 sec</td></tr> <tr><td>1011</td><td>5.4682 sec</td></tr> <tr><td>1100</td><td>10.936 sec</td></tr> <tr><td>1101</td><td>21.873 sec</td></tr> <tr><td>1110</td><td>43.745 sec</td></tr> <tr><td>1111</td><td>87.491 sec</td></tr> </tbody> </table>	Setting	Hold Time	0000	2.67 ms (default)	0001	5.34 ms	0010	10.68 ms	0011	21.36 ms	0100	42.72 ms	0101	85.44 ms	0110	170.88 ms	0111	341.76 ms	1000	683.52 ms	1001	1.367 sec	1010	2.7341 sec	1011	5.4682 sec	1100	10.936 sec	1101	21.873 sec	1110	43.745 sec	1111	87.491 sec
Setting	Hold Time																																			
0000	2.67 ms (default)																																			
0001	5.34 ms																																			
0010	10.68 ms																																			
0011	21.36 ms																																			
0100	42.72 ms																																			
0101	85.44 ms																																			
0110	170.88 ms																																			
0111	341.76 ms																																			
1000	683.52 ms																																			
1001	1.367 sec																																			
1010	2.7341 sec																																			
1011	5.4682 sec																																			
1100	10.936 sec																																			
1101	21.873 sec																																			
1110	43.745 sec																																			
1111	87.491 sec																																			
[3:0]	ALCTARG[3:0]	ALC target. The ALC target sets the desired ADC input level. The PGA gain is adjusted by the ALC to reach this target level. The recommended target level is between –16 dB and –10 dB to accommodate transients without clipping the ADC.																																		
		<table border="1"> <thead> <tr> <th>Setting</th> <th>ALC Target</th> </tr> </thead> <tbody> <tr><td>0000</td><td>–28.5 dB (default)</td></tr> <tr><td>0001</td><td>–27 dB</td></tr> <tr><td>0010</td><td>–25.5 dB</td></tr> <tr><td>0011</td><td>–24 dB</td></tr> <tr><td>0100</td><td>–22.5 dB</td></tr> <tr><td>0101</td><td>–21 dB</td></tr> <tr><td>0110</td><td>–19.5 dB</td></tr> <tr><td>0111</td><td>–18 dB</td></tr> <tr><td>1000</td><td>–16.5 dB</td></tr> <tr><td>1001</td><td>–15 dB</td></tr> <tr><td>1010</td><td>–13.5 dB</td></tr> <tr><td>1011</td><td>–12 dB</td></tr> <tr><td>1100</td><td>–10.5 dB</td></tr> <tr><td>1101</td><td>–9 dB</td></tr> <tr><td>1110</td><td>–7.5 dB</td></tr> <tr><td>1111</td><td>–6 dB</td></tr> </tbody> </table>	Setting	ALC Target	0000	–28.5 dB (default)	0001	–27 dB	0010	–25.5 dB	0011	–24 dB	0100	–22.5 dB	0101	–21 dB	0110	–19.5 dB	0111	–18 dB	1000	–16.5 dB	1001	–15 dB	1010	–13.5 dB	1011	–12 dB	1100	–10.5 dB	1101	–9 dB	1110	–7.5 dB	1111	–6 dB
Setting	ALC Target																																			
0000	–28.5 dB (default)																																			
0001	–27 dB																																			
0010	–25.5 dB																																			
0011	–24 dB																																			
0100	–22.5 dB																																			
0101	–21 dB																																			
0110	–19.5 dB																																			
0111	–18 dB																																			
1000	–16.5 dB																																			
1001	–15 dB																																			
1010	–13.5 dB																																			
1011	–12 dB																																			
1100	–10.5 dB																																			
1101	–9 dB																																			
1110	–7.5 dB																																			
1111	–6 dB																																			

**R13: ALC Control 2 16403 (0x4013)**

<b>Bit 7</b>	<b>Bit 6</b>	<b>Bit 5</b>	<b>Bit 4</b>	<b>Bit 3</b>	<b>Bit 2</b>	<b>Bit 1</b>	<b>Bit 0</b>
ALCATCK[3:0]				ALCDEC[3:0]			

**Table 47. ALC Control 2 Register**

<b>Bit</b>	<b>Bit Name</b>	<b>Description</b>	
[7:4]	ALCATCK[3:0]	ALC attack time. The attack time sets how fast the ALC starts attenuating after an increase in input level above the target. A typical setting for music recording is 384 ms, and a typical setting for voice recording is 24 ms.	
		<b>Setting</b>	<b>Attack Time</b>
		0000	6 ms (default)
		0001	12 ms
		0010	24 ms
		0011	48 ms
		0100	96 ms
		0101	192 ms
		0110	384 ms
		0111	768 ms
		1000	1.54 sec
		1001	3.07 sec
		1010	6.14 sec
		1011	12.29 sec
		1100	24.58 sec
		1101	49.15 sec
1110	98.30 sec		
1111	196.61 sec		
[3:0]	ALCDEC[3:0]	ALC decay time. The decay time sets how fast the ALC increases the PGA gain after a decrease in input level below the target. A typical setting for music recording is 24.58 seconds, and a typical setting for voice recording is 1.54 seconds.	
		<b>Setting</b>	<b>Decay Time</b>
		0000	24 ms
		0001	48 ms
		0010	96 ms
		0011	192 ms
		0100	384 ms
		0101	768 ms
		0110	1.54 sec
		0111	3.07 sec
		1000	6.14 sec
		1001	12.29 sec
		1010	24.58 sec
		1011	49.15 sec
		1100	98.30 sec
		1101	196.61 sec
1110	393.22 sec		
1111	786.43 sec		

# ADAU1761

## R14: ALC Control 3 16404 (0x4014)

Bit 7	Bit 6	Bit 5	Bit 4	Bit 3	Bit 2	Bit 1	Bit 0
NGTYP[1:0]		NGEN	NGTHR[4:0]				

Table 48. ALC Control 3 Register

Bit	Bit Name	Description	
[7:6]	NGTYP[1:0]	Noise gate type. When the input signal falls below the threshold for 250 ms, the noise gate can hold a constant PGA gain, mute the ADC output, fade the PGA gain to the minimum gain value, or fade then mute.	
		<b>Setting</b>	<b>Noise Gate</b>
		00	Hold PGA constant (default)
		01	Mute ADC output (digital mute)
		10	Fade to PGA minimum value (analog fade)
	11	Fade then mute (analog fade/digital mute)	
5	NGEN	Noise gate enable. 0 = disabled (default). 1 = enabled.	
[4:0]	NGTHR[4:0]	Noise gate threshold. When the input signal falls below the threshold for 250 ms, the noise gate is activated. A 1 LSB increase corresponds to a –1.5 dB change. See Table 92 for a complete list of the threshold settings.	
		<b>Setting</b>	<b>Threshold</b>
		00000	–76.5 dB (default)
		00001	–75 dB
		...	...
	11110	–31.5 dB	
	11111	–30 dB	

## R15: Serial Port Control 0 16405 (0x4015)

Bit 7	Bit 6	Bit 5	Bit 4	Bit 3	Bit 2	Bit 1	Bit 0
DITHEN	Reserved	LRMOD	BPOL	LRPOL	CHPF[1:0]		MS

Table 49. Serial Port Control 0 Register

Bit	Bit Name	Description	
7	DITHEN	Dither enable is applicable only for 16-bit data width modes. 0 = disabled (default). 1 = enabled.	
5	LRMOD	LRCLK mode can set the LRCLK for either a 50% duty cycle or a pulse. The pulse mode should be at least 1 BCLK wide. 0 = 50% duty cycle (default). 1 = pulse mode.	
4	BPOL	BCLK polarity sets the BCLK edge that triggers a change in audio data. This can be set for the falling or rising edge of the BCLK. 0 = falling edge (default). 1 = rising edge.	
3	LRPOL	LRCLK polarity sets the LRCLK edge that triggers the beginning of the left channel audio frame. This can be set for the falling or rising edge of the LRCLK. 0 = falling edge (default). 1 = rising edge.	
[2:1]	CHPF[1:0]	Channels per frame sets the number of channels per LRCLK frame.	
		<b>Setting</b>	<b>Channels per LRCLK Frame</b>
		00	Stereo (default)
		01	TDM 4
		10	TDM 8
	11	Reserved	

Bit	Bit Name	Description
0	MS	Serial data port bus mode. Both LRCLK and BCLK are master of the serial port when set in master mode and are serial port slave in slave mode. 0 = slave mode (default). 1 = master mode.

**R16: Serial Port Control 1 16406 (0x4016)**

Bit 7	Bit 6	Bit 5	Bit 4	Bit 3	Bit 2	Bit 1	Bit 0
BPF[2:0]			ADTDM	DATDM	MSBP	LRDEL[1:0]	

**Table 50. Serial Port Control 1 Register**

Bit	Bit Name	Description	
[7:5]	BPF[2:0]	Number of bit clock cycles per LRCLK audio frame.	
		<b>Setting</b>	<b>Bit Clock Cycles</b>
		000	64 (default)
		001	32
		010	48
		011	128
		100	256
		101	Reserved
110	Reserved		
111	Reserved		
4	ADTDM	ADC serial audio data channel position in TDM mode. 0 = left first (default). 1 = right first.	
3	DATDM	DAC serial audio data channel position in TDM mode. 0 = left first (default). 1 = right first.	
2	MSBP	MSB position in the LRCLK frame. 0 = MSB first (default). 1 = LSB first.	
[1:0]	LRDEL[1:0]	Data delay from LRCLK edge (in BCLK units).	
		<b>Setting</b>	<b>Delay (Bit Clock Cycles)</b>
		00	1 (default)
		01	0
		10	8
11	16		

# ADAU1761

## R17: Converter Control 0 16407 (0x4017)

Bit 7	Bit 6	Bit 5	Bit 4	Bit 3	Bit 2	Bit 1	Bit 0
Reserved	DAPAIR[1:0]		DAOSR	ADOSR	CONVSR[2:0]		

Table 51. Converter Control 0 Register

Bit	Bit Name	Description		
[6:5]	DAPAIR[1:0]	On-chip DAC serial audio data selection in TDM 4 or TDM 8 mode.		
		<b>Setting</b>	<b>Pair</b>	
		00	First pair (default)	
		01	Second pair	
		10	Third pair	
		11	Fourth pair	
4	DAOSR	DAC oversampling ratio. 0 = 128× (default). 1 = 64×.		
3	ADOSR	ADC oversampling ratio. 0 = 128× (default). 1 = 64×.		
[2:0]	CONVSR[2:0]	Converter sampling rate. The ADCs and DACs operate at the sampling rate set in this register. The converter rate selected is a ratio of the base sampling rate, $f_s$ . The base sampling rate is determined by the operating frequency of the core clock.		
		<b>Setting</b>	<b>Sampling Rate</b>	<b>Sampling Rate (<math>f_s = 48</math> kHz)</b>
		000	$f_s$	48 kHz, base (default)
		001	$f_s/6$	8 kHz
		010	$f_s/4$	12 kHz
		011	$f_s/3$	16 kHz
		100	$f_s/2$	24 kHz
		101	$f_s/1.5$	32 kHz
		110	$f_s/0.5$	96 kHz
				111



**R18: Converter Control 1 16408 (0x4018)**

Bit 7	Bit 6	Bit 5	Bit 4	Bit 3	Bit 2	Bit 1	Bit 0
Reserved		DAMUTE[1:0]		ADMUTE[1:0]		ADPAIR[1:0]	

**Table 52. Converter Control 1 Register**

Bit	Bit Name	Description	
[5:4]	DAMUTE[1:0]	DAC mute.	
		<b>Setting</b>	<b>Mute/Unmute</b>
		00	Unmute both channels (default)
		01 10 11	Right channel mute Left channel mute Right and left channel mute
[3:2]	ADMUTE[1:0]	ADC mute.	
		<b>Setting</b>	<b>Mute/Unmute</b>
		00	Unmute both channels (default)
		01 10 11	Right channel mute Left channel mute Right and left channel mute
[1:0]	ADPAIR[1:0]	On-chip ADC serial data selection in TDM 4 or TDM 8 mode.	
		<b>Setting</b>	<b>Pair</b>
		00	First pair (default)
		01 10 11	Second pair Third pair Fourth pair

**R19: ADC Control 16409 (0x4019)**

Bit 7	Bit 6	Bit 5	Bit 4	Bit 3	Bit 2	Bit 1	Bit 0
Reserved	ADCPOL	HPF	DMPOL	DMSW	INSEL	ADCEN[1:0]	

**Table 53. ADC Control Register**

Bit	Bit Name	Description	
6	ADCPOL	Invert input polarity. 0 = normal (default). 1 = inverted.	
5	HPF	ADC high-pass filter select. At 48 kHz, $f_{3dB} = 2$ Hz. 0 = off (default). 1 = on.	
4	DMPOL	Digital microphone data polarity swap. 0 = invert polarity. 1 = normal (default).	
3	DMSW	Digital microphone channel swap. Normal operation sends the left channel on the rising edge and the right channel on the falling edge of the clock. 0 = normal (default). 1 = swap left and right channels.	
2	INSEL	Digital microphone input select. When asserted, the on-chip ADCs are off, BCLK is master at $128 \times f_s$ , and ADC_SDATA is expected to have left and right channels interleaved. 0 = digital microphone inputs off, ADCs enabled (default). 1 = digital microphone inputs enabled, ADCs off.	
[1:0]	ADCEN[1:0]	ADC enable.	
		<b>Setting</b>	<b>ADCs Enabled</b>
		00	Both off (default)
		01 10 11	Left on Right on Both on

# ADAU1761

## R20: Left Input Digital Volume 16410 (0x401A)

Bit 7	Bit 6	Bit 5	Bit 4	Bit 3	Bit 2	Bit 1	Bit 0
LADVOL[7:0]							

**Table 54. Left Input Digital Volume Register**

Bit	Bit Name	Description														
[7:0]	LADVOL[7:0]	Controls the digital volume attenuation for left channel inputs from either the left ADC or the left digital microphone input. Each bit corresponds to a 0.375 dB step with slewing between settings. See Table 93 for a complete list of the volume settings.														
		<table border="1"> <thead> <tr> <th>Setting</th> <th>Volume Attenuation</th> </tr> </thead> <tbody> <tr> <td>00000000</td> <td>0 dB (default)</td> </tr> <tr> <td>00000001</td> <td>-0.375 dB</td> </tr> <tr> <td>00000010</td> <td>-0.75 dB</td> </tr> <tr> <td>...</td> <td>...</td> </tr> <tr> <td>11111110</td> <td>-95.25 dB</td> </tr> <tr> <td>11111111</td> <td>-95.625 dB</td> </tr> </tbody> </table>	Setting	Volume Attenuation	00000000	0 dB (default)	00000001	-0.375 dB	00000010	-0.75 dB	...	...	11111110	-95.25 dB	11111111	-95.625 dB
Setting	Volume Attenuation															
00000000	0 dB (default)															
00000001	-0.375 dB															
00000010	-0.75 dB															
...	...															
11111110	-95.25 dB															
11111111	-95.625 dB															

## R21: Right Input Digital Volume 16411 (0x401B)

Bit 7	Bit 6	Bit 5	Bit 4	Bit 3	Bit 2	Bit 1	Bit 0
RADVOL[7:0]							

**Table 55. Right Input Digital Volume Register**

Bit	Bit Name	Description														
[7:0]	RADVOL[7:0]	Controls the digital volume attenuation for right channel inputs from either the right ADC or the right digital microphone input. Each bit corresponds to a 0.375 dB step with slewing between settings. See Table 93 for a complete list of the volume settings.														
		<table border="1"> <thead> <tr> <th>Setting</th> <th>Volume Attenuation</th> </tr> </thead> <tbody> <tr> <td>00000000</td> <td>0 dB (default)</td> </tr> <tr> <td>00000001</td> <td>-0.375 dB</td> </tr> <tr> <td>00000010</td> <td>-0.75 dB</td> </tr> <tr> <td>...</td> <td>...</td> </tr> <tr> <td>11111110</td> <td>-95.25 dB</td> </tr> <tr> <td>11111111</td> <td>-95.625 dB</td> </tr> </tbody> </table>	Setting	Volume Attenuation	00000000	0 dB (default)	00000001	-0.375 dB	00000010	-0.75 dB	...	...	11111110	-95.25 dB	11111111	-95.625 dB
Setting	Volume Attenuation															
00000000	0 dB (default)															
00000001	-0.375 dB															
00000010	-0.75 dB															
...	...															
11111110	-95.25 dB															
11111111	-95.625 dB															

**R22: Playback Mixer Left (Mixer 3) Control 0 16412 (0x401C)**

Bit 7	Bit 6	Bit 5	Bit 4	Bit 3	Bit 2	Bit 1	Bit 0
Reserved	MX3RM	MX3LM	MX3AUXG[3:0]				MX3EN

**Table 56. Playback Mixer Left (Mixer 3) Control 0 Register**

Bit	Bit Name	Description																				
6	MX3RM	Mixer input mute. Mutes the right DAC input to the left channel playback mixer (Mixer 3). 0 = muted (default). 1 = unmuted.																				
5	MX3LM	Mixer input mute. Mutes the left DAC input to the left channel playback mixer (Mixer 3). 0 = muted (default). 1 = unmuted.																				
[4:1]	MX3AUXG[3:0]	Mixer input gain. Controls the left channel auxiliary input gain to the left channel playback mixer (Mixer 3).																				
		<table border="1"> <thead> <tr> <th>Setting</th> <th>Gain</th> </tr> </thead> <tbody> <tr> <td>0000</td> <td>Mute (default)</td> </tr> <tr> <td>0001</td> <td>-15 dB</td> </tr> <tr> <td>0010</td> <td>-12 dB</td> </tr> <tr> <td>0011</td> <td>-9 dB</td> </tr> <tr> <td>0100</td> <td>-6 dB</td> </tr> <tr> <td>0101</td> <td>-3 dB</td> </tr> <tr> <td>0110</td> <td>0 dB</td> </tr> <tr> <td>0111</td> <td>3 dB</td> </tr> <tr> <td>1000</td> <td>6 dB</td> </tr> </tbody> </table>	Setting	Gain	0000	Mute (default)	0001	-15 dB	0010	-12 dB	0011	-9 dB	0100	-6 dB	0101	-3 dB	0110	0 dB	0111	3 dB	1000	6 dB
Setting	Gain																					
0000	Mute (default)																					
0001	-15 dB																					
0010	-12 dB																					
0011	-9 dB																					
0100	-6 dB																					
0101	-3 dB																					
0110	0 dB																					
0111	3 dB																					
1000	6 dB																					
0	MX3EN	Mixer 3 enable. 0 = disabled (default). 1 = enabled.																				

# ADAU1761

## R23: Playback Mixer Left (Mixer 3) Control 1 16413 (0x401D)

Bit 7	Bit 6	Bit 5	Bit 4	Bit 3	Bit 2	Bit 1	Bit 0
MX3G2[3:0]				MX3G1[3:0]			

Table 57. Playback Mixer Left (Mixer 3) Control 1 Register

Bit	Bit Name	Description	
[7:4]	MX3G2[3:0]	Bypass gain control. The signal from the right channel record mixer (Mixer 2) bypasses the converters and gain can be applied before the left playback mixer (Mixer 3).	
		<b>Setting</b>	<b>Gain</b>
		0000	Mute (default)
		0001	-15 dB
		0010	-12 dB
		0011	-9 dB
		0100	-6 dB
		0101	-3 dB
		0110	0 dB
		0111	3 dB
1000	6 dB		
[3:0]	MX3G1[3:0]	Bypass gain control. The signal from the left channel record mixer (Mixer 1) bypasses the converters and gain can be applied before the left playback mixer (Mixer 3).	
		<b>Setting</b>	<b>Gain</b>
		0000	Mute (default)
		0001	-15 dB
		0010	-12 dB
		0011	-9 dB
		0100	-6 dB
		0101	-3 dB
		0110	0 dB
		0111	3 dB
1000	6 dB		

**R24: Playback Mixer Right (Mixer 4) Control 0 16414 (0x401E)**

Bit 7	Bit 6	Bit 5	Bit 4	Bit 3	Bit 2	Bit 1	Bit 0
Reserved	MX4RM	MX4LM	MX4AUXG[3:0]				MX4EN

**Table 58. Playback Mixer Right (Mixer 4) Control 0 Register**

Bit	Bit Name	Description																				
6	MX4RM	Mixer input mute. Mutes the right DAC input to the right channel playback mixer (Mixer 4). 0 = muted (default). 1 = unmuted.																				
5	MX4LM	Mixer input mute. Mutes the left DAC input to the right channel playback mixer (Mixer 4). 0 = muted (default). 1 = unmuted.																				
[4:1]	MX4AUXG[3:0]	Mixer input gain. Controls the right channel auxiliary input gain to the right channel playback mixer (Mixer 4).																				
		<table border="1"> <thead> <tr> <th>Setting</th> <th>Gain</th> </tr> </thead> <tbody> <tr> <td>0000</td> <td>Mute (default)</td> </tr> <tr> <td>0001</td> <td>-15 dB</td> </tr> <tr> <td>0010</td> <td>-12 dB</td> </tr> <tr> <td>0011</td> <td>-9 dB</td> </tr> <tr> <td>0100</td> <td>-6 dB</td> </tr> <tr> <td>0101</td> <td>-3 dB</td> </tr> <tr> <td>0110</td> <td>0 dB</td> </tr> <tr> <td>0111</td> <td>3 dB</td> </tr> <tr> <td>1000</td> <td>6 dB</td> </tr> </tbody> </table>	Setting	Gain	0000	Mute (default)	0001	-15 dB	0010	-12 dB	0011	-9 dB	0100	-6 dB	0101	-3 dB	0110	0 dB	0111	3 dB	1000	6 dB
Setting	Gain																					
0000	Mute (default)																					
0001	-15 dB																					
0010	-12 dB																					
0011	-9 dB																					
0100	-6 dB																					
0101	-3 dB																					
0110	0 dB																					
0111	3 dB																					
1000	6 dB																					
0	MX4EN	Mixer 4 enable. 0 = disabled (default). 1 = enabled.																				

# ADAU1761

## R25: Playback Mixer Right (Mixer 4) Control 1 16415 (0x401F)

Bit 7	Bit 6	Bit 5	Bit 4	Bit 3	Bit 2	Bit 1	Bit 0
MX4G2[3:0]				MX4G1[3:0]			

Table 59. Playback Mixer Right (Mixer 4) Control 1 Register

Bit	Bit Name	Description	
[7:4]	MX4G2[3:0]	Bypass gain control. The signal from the right channel record mixer (Mixer 2) bypasses the converters and gain can be applied before the right playback mixer (Mixer 4).	
		<b>Setting</b>	<b>Gain</b>
		0000	Mute (default)
		0001	-15 dB
		0010	-12 dB
		0011	-9 dB
		0100	-6 dB
		0101	-3 dB
		0110	0 dB
		0111	3 dB
1000	6 dB		
[3:0]	MX4G1[3:0]	Bypass gain control. The signal from the left channel record mixer (Mixer 1) bypasses the converters and gain can be applied before the right playback mixer (Mixer 4).	
		<b>Setting</b>	<b>Gain</b>
		0000	Mute (default)
		0001	-15 dB
		0010	-12 dB
		0011	-9 dB
		0100	-6 dB
		0101	-3 dB
		0110	0 dB
		0111	3 dB
1000	6 dB		

**R26: Playback L/R Mixer Left (Mixer 5) Line Output Control 16416 (0x4020)**

<b>Bit 7</b>	<b>Bit 6</b>	<b>Bit 5</b>	<b>Bit 4</b>	<b>Bit 3</b>	<b>Bit 2</b>	<b>Bit 1</b>	<b>Bit 0</b>
Reserved			MX5G4[1:0]		MX5G3[1:0]		MX5EN

**Table 60. Playback L/R Mixer Left (Mixer 5) Line Output Control Register**

Bit	Bit Name	Description										
[4:3]	MX5G4[1:0]	Mixer input gain boost. The signal from the right channel playback mixer (Mixer 4) can be boosted in the L/R left playback mixer (Mixer 5).										
		<table border="1"> <thead> <tr> <th>Setting</th> <th>Gain Boost</th> </tr> </thead> <tbody> <tr> <td>00</td> <td>Mute (default)</td> </tr> <tr> <td>01</td> <td>0 dB</td> </tr> <tr> <td>10</td> <td>6 dB</td> </tr> <tr> <td>11</td> <td>Reserved</td> </tr> </tbody> </table>	Setting	Gain Boost	00	Mute (default)	01	0 dB	10	6 dB	11	Reserved
		Setting	Gain Boost									
		00	Mute (default)									
01	0 dB											
10	6 dB											
11	Reserved											
[2:1]	MX5G3[1:0]	Mixer input gain boost. The signal from the left channel playback mixer (Mixer 3) can be boosted in the L/R left playback mixer (Mixer 5).										
		<table border="1"> <thead> <tr> <th>Setting</th> <th>Gain Boost</th> </tr> </thead> <tbody> <tr> <td>00</td> <td>Mute (default)</td> </tr> <tr> <td>01</td> <td>0 dB</td> </tr> <tr> <td>10</td> <td>6 dB</td> </tr> <tr> <td>11</td> <td>Reserved</td> </tr> </tbody> </table>	Setting	Gain Boost	00	Mute (default)	01	0 dB	10	6 dB	11	Reserved
		Setting	Gain Boost									
		00	Mute (default)									
01	0 dB											
10	6 dB											
11	Reserved											
0	MX5EN	Mixer 5 enable. 0 = disabled (default). 1 = enabled.										

**R27: Playback L/R Mixer Right (Mixer 6) Line Output Control 16417 (0x4021)**

<b>Bit 7</b>	<b>Bit 6</b>	<b>Bit 5</b>	<b>Bit 4</b>	<b>Bit 3</b>	<b>Bit 2</b>	<b>Bit 1</b>	<b>Bit 0</b>
Reserved			MX6G3[1:0]		MX6G4[1:0]		MX6EN

**Table 61. Playback L/R Mixer Right (Mixer 6) Line Output Control Register**

Bit	Bit Name	Description										
[4:3]	MX6G3[1:0]	Mixer input gain boost. The signal from the left channel playback mixer (Mixer 3) can be boosted in the L/R right playback mixer (Mixer 6).										
		<table border="1"> <thead> <tr> <th>Setting</th> <th>Gain Boost</th> </tr> </thead> <tbody> <tr> <td>00</td> <td>Mute (default)</td> </tr> <tr> <td>01</td> <td>0 dB</td> </tr> <tr> <td>10</td> <td>6 dB</td> </tr> <tr> <td>11</td> <td>Reserved</td> </tr> </tbody> </table>	Setting	Gain Boost	00	Mute (default)	01	0 dB	10	6 dB	11	Reserved
		Setting	Gain Boost									
		00	Mute (default)									
01	0 dB											
10	6 dB											
11	Reserved											
[2:1]	MX6G4[1:0]	Mixer input gain boost. The signal from the right channel playback mixer (Mixer 4) can be boosted in the L/R right playback mixer (Mixer 6).										
		<table border="1"> <thead> <tr> <th>Setting</th> <th>Gain Boost</th> </tr> </thead> <tbody> <tr> <td>00</td> <td>Mute (default)</td> </tr> <tr> <td>01</td> <td>0 dB</td> </tr> <tr> <td>10</td> <td>6 dB</td> </tr> <tr> <td>11</td> <td>Reserved</td> </tr> </tbody> </table>	Setting	Gain Boost	00	Mute (default)	01	0 dB	10	6 dB	11	Reserved
		Setting	Gain Boost									
		00	Mute (default)									
01	0 dB											
10	6 dB											
11	Reserved											
0	MX6EN	Mixer 6 enable. 0 = disabled (default). 1 = enabled.										

# ADAU1761

## R28: Playback L/R Mixer Mono Output (Mixer 7) Control 16418 (0x4022)

Bit 7	Bit 6	Bit 5	Bit 4	Bit 3	Bit 2	Bit 1	Bit 0
Reserved					MX7[1:0]		MX7EN

Table 62. Playback L/R Mixer Mono Output (Mixer 7) Control Register

Bit	Bit Name	Description										
[2:1]	MX7[1:0]	L/R mono playback mixer (Mixer 7). Mixes the left and right playback mixers (Mixer 3 and Mixer 4) with either a 0 dB or 6 dB gain boost. Additionally, this mixer can operate as a common-mode output, which is used as the virtual ground in a capless headphone configuration.										
		<table border="1"> <thead> <tr> <th>Setting</th> <th>Gain Boost</th> </tr> </thead> <tbody> <tr> <td>00</td> <td>Common-mode output (default)</td> </tr> <tr> <td>01</td> <td>0 dB</td> </tr> <tr> <td>10</td> <td>6 dB</td> </tr> <tr> <td>11</td> <td>Reserved</td> </tr> </tbody> </table>	Setting	Gain Boost	00	Common-mode output (default)	01	0 dB	10	6 dB	11	Reserved
Setting	Gain Boost											
00	Common-mode output (default)											
01	0 dB											
10	6 dB											
11	Reserved											
0	MX7EN	Mixer 7 enable. 0 = disabled (default). 1 = enabled.										

## R29: Playback Headphone Left Volume Control 16419 (0x4023)

Bit 7	Bit 6	Bit 5	Bit 4	Bit 3	Bit 2	Bit 1	Bit 0
LHPVOL[5:0]						LHPM	HPDUAL

Table 63. Playback Headphone Left Volume Control Register

Bit	Bit Name	Description												
[7:2]	LHPVOL[5:0]	Headphone volume control for left channel, LHP output. Each 1-bit step corresponds to a 1 dB increase in volume. See Table 94 for a complete list of the volume settings.												
		<table border="1"> <thead> <tr> <th>Setting</th> <th>Volume</th> </tr> </thead> <tbody> <tr> <td>000000</td> <td>-57 dB (default)</td> </tr> <tr> <td>...</td> <td>...</td> </tr> <tr> <td>111001</td> <td>0 dB</td> </tr> <tr> <td>...</td> <td>...</td> </tr> <tr> <td>111111</td> <td>6 dB</td> </tr> </tbody> </table>	Setting	Volume	000000	-57 dB (default)	...	...	111001	0 dB	...	...	111111	6 dB
Setting	Volume													
000000	-57 dB (default)													
...	...													
111001	0 dB													
...	...													
111111	6 dB													
1	LHPM	Headphone mute for left channel, LHP output (active low). 0 = mute. 1 = unmute (default).												
0	HPDUAL	Link left and right channel headphone volume for dual channel control. 0 = disabled (default). 1 = enabled.												



**R30: Playback Headphone Right Volume Control 16420 (0x4024)**

Bit 7	Bit 6	Bit 5	Bit 4	Bit 3	Bit 2	Bit 1	Bit 0
RHPVOL[5:0]						RHPM	HPMODE

**Table 64. Playback Headphone Right Volume Control Register**

Bit	Bit Name	Description										
[7:2]	RHPVOL[5:0]	Headphone volume control for right channel, RHP output. Each 1-bit step corresponds to a 1 dB increase in volume. See Table 94 for a complete list of the volume settings.										
		<table border="1"> <thead> <tr> <th>Setting</th> <th>Volume</th> </tr> </thead> <tbody> <tr> <td>000000</td> <td>-57 dB (default)</td> </tr> <tr> <td>...</td> <td>...</td> </tr> <tr> <td>111001</td> <td>0 dB</td> </tr> <tr> <td>...</td> <td>...</td> </tr> <tr> <td>111111</td> <td>6 dB</td> </tr> </tbody> </table>	Setting	Volume	000000	-57 dB (default)	...	...	111001	0 dB	...	...
Setting	Volume											
000000	-57 dB (default)											
...	...											
111001	0 dB											
...	...											
111111	6 dB											
1	RHPM	Headphone mute for right channel, RHP output (active low). 0 = mute. 1 = unmute (default).										
0	HPMODE	RHP and LHP output mode. These pins can be configured for either line outputs or headphone outputs. 0 = line output (default). 1 = headphone output.										

**R31: Playback Line Output Left Volume Control 16421 (0x4025)**

Bit 7	Bit 6	Bit 5	Bit 4	Bit 3	Bit 2	Bit 1	Bit 0
LOUTVOL[5:0]						LOUTM	LOMODE

**Table 65. Playback Line Output Left Volume Control Register**

Bit	Bit Name	Description										
[7:2]	LOUTVOL[5:0]	Line output volume control for left channel, LOUTN and LOUTP outputs. Each 1-bit step corresponds to a 1 dB increase in volume. See Table 94 for a complete list of the volume settings.										
		<table border="1"> <thead> <tr> <th>Setting</th> <th>Volume</th> </tr> </thead> <tbody> <tr> <td>000000</td> <td>-57 dB (default)</td> </tr> <tr> <td>...</td> <td>...</td> </tr> <tr> <td>111001</td> <td>0 dB</td> </tr> <tr> <td>...</td> <td>...</td> </tr> <tr> <td>111111</td> <td>6 dB</td> </tr> </tbody> </table>	Setting	Volume	000000	-57 dB (default)	...	...	111001	0 dB	...	...
Setting	Volume											
000000	-57 dB (default)											
...	...											
111001	0 dB											
...	...											
111111	6 dB											
1	LOUTM	Line output mute for left channel, LOUTN and LOUTP outputs (active low). 0 = mute. 1 = unmute (default).										
0	LOMODE	Line output mode for left channel, LOUTN and LOUTP outputs. These pins can be configured for either line outputs or headphone outputs. To drive earpiece speakers, set this bit to 1 (headphone output). 0 = line output (default). 1 = headphone output.										

# ADAU1761

## R32: Playback Line Output Right Volume Control 16422 (0x4026)

Bit 7	Bit 6	Bit 5	Bit 4	Bit 3	Bit 2	Bit 1	Bit 0
ROUTVOL[5:0]						ROUTM	ROMODE

**Table 66. Playback Line Output Right Volume Control Register**

Bit	Bit Name	Description												
[7:2]	ROUTVOL[5:0]	Line output volume control for right channel, ROUTN and ROUTP outputs. Each 1-bit step corresponds to a 1 dB increase in volume. See Table 94 for a complete list of the volume settings.												
		<table border="1"> <thead> <tr> <th>Setting</th> <th>Volume</th> </tr> </thead> <tbody> <tr> <td>000000</td> <td>-57 dB (default)</td> </tr> <tr> <td>...</td> <td>...</td> </tr> <tr> <td>111001</td> <td>0 dB</td> </tr> <tr> <td>...</td> <td>...</td> </tr> <tr> <td>111111</td> <td>6 dB</td> </tr> </tbody> </table>	Setting	Volume	000000	-57 dB (default)	...	...	111001	0 dB	...	...	111111	6 dB
Setting	Volume													
000000	-57 dB (default)													
...	...													
111001	0 dB													
...	...													
111111	6 dB													
1	ROUTM	Line output mute for right channel, ROUTN and ROUTP outputs (active low). 0 = mute. 1 = unmute (default).												
0	ROMODE	Line output mode for right channel, ROUTN and ROUTP outputs. These pins can be configured for either line outputs or headphone outputs. To drive earpiece speakers, set this bit to 1 (headphone output). 0 = line output (default). 1 = headphone output.												

## R33: Playback Mono Output Control 16423 (0x4027)

Bit 7	Bit 6	Bit 5	Bit 4	Bit 3	Bit 2	Bit 1	Bit 0
MONOVOL[5:0]						MONOM	MOMODE

**Table 67. Playback Mono Output Control Register**

Bit	Bit Name	Description												
[7:2]	MONOVOL[5:0]	Mono output volume control. Each 1-bit step corresponds to a 1 dB increase in volume. If MX7[1:0] in Register R28 is set for common-mode output, volume control is disabled. See Table 94 for a complete list of the volume settings.												
		<table border="1"> <thead> <tr> <th>Setting</th> <th>Volume</th> </tr> </thead> <tbody> <tr> <td>000000</td> <td>-57 dB (default)</td> </tr> <tr> <td>...</td> <td>...</td> </tr> <tr> <td>111001</td> <td>0 dB</td> </tr> <tr> <td>...</td> <td>...</td> </tr> <tr> <td>111111</td> <td>6 dB</td> </tr> </tbody> </table>	Setting	Volume	000000	-57 dB (default)	...	...	111001	0 dB	...	...	111111	6 dB
Setting	Volume													
000000	-57 dB (default)													
...	...													
111001	0 dB													
...	...													
111111	6 dB													
1	MONOM	Mono output mute (active low). 0 = mute. 1 = unmute (default).												
0	MOMODE	Headphone mode enable. If MX7[1:0] in Register R28 is set for common-mode output for a capless headphone configuration, this bit should be set to 1 (headphone output). 0 = line output (default). 1 = headphone output.												

**R34: Playback Pop/Click Suppression 16424 (0x4028)**

Bit 7	Bit 6	Bit 5	Bit 4	Bit 3	Bit 2	Bit 1	Bit 0
Reserved			POPMODE	Popless	ASLEW[1:0]		Reserved

**Table 68. Playback Pop/Click Suppression Register**

Bit	Bit Name	Description										
4	POPMODE	Pop suppression circuit power saving mode. The pop suppression circuits charge faster in normal operation; however, after they are charged, they can be put into low power operation. 0 = normal (default). 1 = low power.										
3	Popless	Pop suppression disable. The pop suppression circuits are enabled by default. They can be disabled to save power; however, disabling the circuits increases the risk of pops and clicks. 0 = enabled (default). 1 = disabled.										
[2:1]	ASLEW[1:0]	Analog volume slew rate for playback volume controls.										
		<table border="1"> <thead> <tr> <th>Setting</th> <th>Slew Rate</th> </tr> </thead> <tbody> <tr> <td>00</td> <td>21.25 ms (default)</td> </tr> <tr> <td>01</td> <td>42.5 ms</td> </tr> <tr> <td>10</td> <td>85 ms</td> </tr> <tr> <td>11</td> <td>Off</td> </tr> </tbody> </table>	Setting	Slew Rate	00	21.25 ms (default)	01	42.5 ms	10	85 ms	11	Off
Setting	Slew Rate											
00	21.25 ms (default)											
01	42.5 ms											
10	85 ms											
11	Off											

**R35: Playback Power Management 16425 (0x4029)**

Bit 7	Bit 6	Bit 5	Bit 4	Bit 3	Bit 2	Bit 1	Bit 0
HPBIAS[1:0]		DACBIAS[1:0]		PBIAS[1:0]		PREN	PLEN

**Table 69. Playback Power Management Register**

Bit	Bit Name	Description										
[7:6]	HPBIAS[1:0]	Headphone bias control.										
		<table border="1"> <thead> <tr> <th>Setting</th> <th>Headphone Bias Control</th> </tr> </thead> <tbody> <tr> <td>00</td> <td>Normal operation (default)</td> </tr> <tr> <td>01</td> <td>Extreme power saving</td> </tr> <tr> <td>10</td> <td>Enhanced performance</td> </tr> <tr> <td>11</td> <td>Power saving</td> </tr> </tbody> </table>	Setting	Headphone Bias Control	00	Normal operation (default)	01	Extreme power saving	10	Enhanced performance	11	Power saving
Setting	Headphone Bias Control											
00	Normal operation (default)											
01	Extreme power saving											
10	Enhanced performance											
11	Power saving											
[5:4]	DACBIAS[1:0]	DAC bias control.										
		<table border="1"> <thead> <tr> <th>Setting</th> <th>DAC Bias Control</th> </tr> </thead> <tbody> <tr> <td>00</td> <td>Normal operation (default)</td> </tr> <tr> <td>01</td> <td>Extreme power saving</td> </tr> <tr> <td>10</td> <td>Enhanced performance</td> </tr> <tr> <td>11</td> <td>Power saving</td> </tr> </tbody> </table>	Setting	DAC Bias Control	00	Normal operation (default)	01	Extreme power saving	10	Enhanced performance	11	Power saving
Setting	DAC Bias Control											
00	Normal operation (default)											
01	Extreme power saving											
10	Enhanced performance											
11	Power saving											
[3:2]	PBIAS[1:0]	Playback path channel bias control.										
		<table border="1"> <thead> <tr> <th>Setting</th> <th>Playback Path Bias Control</th> </tr> </thead> <tbody> <tr> <td>00</td> <td>Normal operation (default)</td> </tr> <tr> <td>01</td> <td>Reserved</td> </tr> <tr> <td>10</td> <td>Enhanced performance</td> </tr> <tr> <td>11</td> <td>Power saving</td> </tr> </tbody> </table>	Setting	Playback Path Bias Control	00	Normal operation (default)	01	Reserved	10	Enhanced performance	11	Power saving
Setting	Playback Path Bias Control											
00	Normal operation (default)											
01	Reserved											
10	Enhanced performance											
11	Power saving											
1	PREN	Playback right channel enable. 0 = disabled (default). 1 = enabled.										
0	PLEN	Playback left channel enable. 0 = disabled (default). 1 = enabled.										

# ADAU1761

## R36: DAC Control 0 16426 (0x402A)

Bit 7	Bit 6	Bit 5	Bit 4	Bit 3	Bit 2	Bit 1	Bit 0
DACMONO[1:0]		DACPOL	Reserved		DEMPH	DACEN[1:0]	

Table 70. DAC Control 0 Register

Bit	Bit Name	Description	
[7:6]	DACMONO[1:0]	DAC mono mode. The DAC channels can be set to mono mode within the DAC and output on the left channel, the right channel, or both channels.	
		<b>Setting</b>	<b>Mono Mode</b>
		00	Stereo (default)
		01	Left channel in mono mode
		10	Right channel in mono mode
	11	Both channels in mono mode	
5	DACPOL	Invert input polarity of the DACs. 0 = normal (default). 1 = inverted.	
2	DEMPH	DAC de-emphasis filter enable. The de-emphasis filter is designed for use with a sampling rate of 44.1 kHz only. 0 = disabled (default). 1 = enabled.	
[1:0]	DACEN[1:0]	DAC enable.	
		<b>Setting</b>	<b>DACs Enabled</b>
		00	Both off (default)
		01	Left on
		10	Right on
	11	Both on	

## R37: DAC Control 1 16427 (0x402B)

Bit 7	Bit 6	Bit 5	Bit 4	Bit 3	Bit 2	Bit 1	Bit 0
LDAVOL[7:0]							

Table 71. DAC Control 1 Register

Bit	Bit Name	Description	
[7:0]	LDAVOL[7:0]	Controls the digital volume attenuation for left channel inputs from the left DAC. Each bit corresponds to a 0.375 dB step with slewing between settings. See Table 93 for a complete list of the volume settings.	
		<b>Setting</b>	<b>Volume Attenuation</b>
		00000000	0 dB (default)
		00000001	-0.375 dB
		00000010	-0.75 dB
		...	...
		11111110	-95.25 dB
11111111	-95.625 dB		

**R38: DAC Control 2 16428 (0x402C)**

Bit 7	Bit 6	Bit 5	Bit 4	Bit 3	Bit 2	Bit 1	Bit 0
RDAVOL[7:0]							

**Table 72. DAC Control 2 Register**

Bit	Bit Name	Description														
[7:0]	RDAVOL[7:0]	Controls the digital volume attenuation for right channel inputs from the right DAC. Each bit corresponds to a 0.375 dB step with slewing between settings. See Table 93 for a complete list of the volume settings.														
		<table border="1"> <thead> <tr> <th>Setting</th> <th>Volume Attenuation</th> </tr> </thead> <tbody> <tr> <td>00000000</td> <td>0 dB (default)</td> </tr> <tr> <td>00000001</td> <td>-0.375 dB</td> </tr> <tr> <td>00000010</td> <td>-0.75 dB</td> </tr> <tr> <td>...</td> <td>...</td> </tr> <tr> <td>11111110</td> <td>-95.25 dB</td> </tr> <tr> <td>11111111</td> <td>-95.625 dB</td> </tr> </tbody> </table>	Setting	Volume Attenuation	00000000	0 dB (default)	00000001	-0.375 dB	00000010	-0.75 dB	...	...	11111110	-95.25 dB	11111111	-95.625 dB
Setting	Volume Attenuation															
00000000	0 dB (default)															
00000001	-0.375 dB															
00000010	-0.75 dB															
...	...															
11111110	-95.25 dB															
11111111	-95.625 dB															

**R39: Serial Port Pad Control 16429 (0x402D)**

The optional pull-up/pull-down resistors are nominally 250 kΩ. When enabled, these pull-up/pull-down resistors set the serial port signals to a defined state when the signal source becomes three-state.

Bit 7	Bit 6	Bit 5	Bit 4	Bit 3	Bit 2	Bit 1	Bit 0
ADCSDP[1:0]		DACSDP[1:0]		LRCLKP[1:0]		BCLKP[1:0]	

**Table 73. Serial Port Pad Control Register**

Bit	Bit Name	Description										
[7:6]	ADCSDP[1:0]	ADC_SDATA pad pull-up/pull-down configuration.										
		<table border="1"> <thead> <tr> <th>Setting</th> <th>Configuration</th> </tr> </thead> <tbody> <tr> <td>00</td> <td>Pull-up</td> </tr> <tr> <td>01</td> <td>Reserved</td> </tr> <tr> <td>10</td> <td>None (default)</td> </tr> <tr> <td>11</td> <td>Pull-down</td> </tr> </tbody> </table>	Setting	Configuration	00	Pull-up	01	Reserved	10	None (default)	11	Pull-down
Setting	Configuration											
00	Pull-up											
01	Reserved											
10	None (default)											
11	Pull-down											
[5:4]	DACSDP[1:0]	DAC_SDATA pad pull-up/pull-down configuration.										
		<table border="1"> <thead> <tr> <th>Setting</th> <th>Configuration</th> </tr> </thead> <tbody> <tr> <td>00</td> <td>Pull-up</td> </tr> <tr> <td>01</td> <td>Reserved</td> </tr> <tr> <td>10</td> <td>None (default)</td> </tr> <tr> <td>11</td> <td>Pull-down</td> </tr> </tbody> </table>	Setting	Configuration	00	Pull-up	01	Reserved	10	None (default)	11	Pull-down
Setting	Configuration											
00	Pull-up											
01	Reserved											
10	None (default)											
11	Pull-down											
[3:2]	LRCLKP[1:0]	LRCLK pad pull-up/pull-down configuration.										
		<table border="1"> <thead> <tr> <th>Setting</th> <th>Configuration</th> </tr> </thead> <tbody> <tr> <td>00</td> <td>Pull-up</td> </tr> <tr> <td>01</td> <td>Reserved</td> </tr> <tr> <td>10</td> <td>None (default)</td> </tr> <tr> <td>11</td> <td>Pull-down</td> </tr> </tbody> </table>	Setting	Configuration	00	Pull-up	01	Reserved	10	None (default)	11	Pull-down
Setting	Configuration											
00	Pull-up											
01	Reserved											
10	None (default)											
11	Pull-down											
[1:0]	BCLKP[1:0]	BCLK pad pull-up/pull-down configuration.										
		<table border="1"> <thead> <tr> <th>Setting</th> <th>Configuration</th> </tr> </thead> <tbody> <tr> <td>00</td> <td>Pull-up</td> </tr> <tr> <td>01</td> <td>Reserved</td> </tr> <tr> <td>10</td> <td>None (default)</td> </tr> <tr> <td>11</td> <td>Pull-down</td> </tr> </tbody> </table>	Setting	Configuration	00	Pull-up	01	Reserved	10	None (default)	11	Pull-down
Setting	Configuration											
00	Pull-up											
01	Reserved											
10	None (default)											
11	Pull-down											

# ADAU1761

## R40: Control Port Pad Control 0 16431 (0x402F)

The optional pull-up/pull-down resistors are nominally 250 kΩ. When enabled, these pull-up/pull-down resistors set the control port signals to a defined state when the signal source becomes three-state.

Bit 7	Bit 6	Bit 5	Bit 4	Bit 3	Bit 2	Bit 1	Bit 0
CDATP[1:0]		CLCHP[1:0]		SCLP[1:0]		SDAP[1:0]	

Table 74. Control Port Pad Control 0 Register

Bit	Bit Name	Description	
[7:6]	CDATP[1:0]	CDATA pad pull-up/pull-down configuration.	
		<b>Setting</b>	<b>Configuration</b>
		00	Pull-up
		01	Reserved
		10	None (default)
[5:4]	CLCHP[1:0]	CLATCH pad pull-up/pull-down configuration.	
		<b>Setting</b>	<b>Configuration</b>
		00	Pull-up
		01	Reserved
		10	None (default)
[3:2]	SCLP[1:0]	SCL/CCLK pad pull-up/pull-down configuration.	
		<b>Setting</b>	<b>Configuration</b>
		00	Pull-up
		01	Reserved
		10	None (default)
[1:0]	SDAP[1:0]	SDA/COUT pad pull-up/pull-down configuration.	
		<b>Setting</b>	<b>Configuration</b>
		00	Pull-up
		01	Reserved
		10	None (default)
		11	Pull-down

## R41: Control Port Pad Control 1 16432 (0x4030)

With IOVDD set to 3.3 V, the low and high drive strengths of the SDA/COUT pin are approximately 2.0 mA and 4.0 mA, respectively. With IOVDD set to 1.8 V, the low and high drive strengths are approximately 0.8 mA and 1.7 mA, respectively. The high drive strength mode may be useful for generating a stronger ACK pulse in I<sup>2</sup>C mode, if needed.

Bit 7	Bit 6	Bit 5	Bit 4	Bit 3	Bit 2	Bit 1	Bit 0
Reserved							SDASTR

Table 75. Control Port Pad Control 1 Register

Bit	Bit Name	Description
0	SDASTR	SDA/COUT pin drive strength. 0 = low (default). 1 = high.

**R42: Jack Detect Pin Control 16433 (0x4031)**

Bit 7	Bit 6	Bit 5	Bit 4	Bit 3	Bit 2	Bit 1	Bit 0
Reserved		JDSTR	Reserved	JDP[1:0]		Reserved	

**Table 76. Jack Detect Pin Control Register**

Bit	Bit Name	Description										
5	JDSTR	JACKDET/MICIN drive strength. 0 = low (default). 1 = high.										
[3:2]	JDP[1:0]	JACKDET/MICIN pad pull-up/pull-down configuration.										
		<table border="1"> <thead> <tr> <th>Setting</th> <th>Configuration</th> </tr> </thead> <tbody> <tr> <td>00</td> <td>Pull-up</td> </tr> <tr> <td>01</td> <td>Reserved</td> </tr> <tr> <td>10</td> <td>None (default)</td> </tr> <tr> <td>11</td> <td>Pull-down</td> </tr> </tbody> </table>	Setting	Configuration	00	Pull-up	01	Reserved	10	None (default)	11	Pull-down
Setting	Configuration											
00	Pull-up											
01	Reserved											
10	None (default)											
11	Pull-down											

**R43 to R47: Cyclic Redundancy Check Registers 16576 to 16580 (0x40C0 to 0x40C4)**

The cyclic redundancy check (CRC) constantly checks the validity of the program RAM contents. SigmaStudio generates a 32-bit hash sum, which must be written to four consecutive read-only 8-bit register locations. CRC must then be enabled. Every 1024 frames (21 ms at 48 kHz), the IC generates its own 32-bit code and compares it to the one stored in these registers. If the codes do not match, a GPIO pin is set high (CRC flag). This output flag must be enabled using the output CRC error sticky setting in the GPIO pin control register (see Table 78). The 1-bit CRC error flag is reset when the CRCEN bit goes low. For example, a GPIO pin can be connected to an interrupt pin on an external microcontroller, which triggers a rewrite of the corrupted memory.

By default, CRC is disabled (the CRCEN bit is set to 0). To enable continuous CRC checking, the user can set the CRCEN bit to 1 after loading a program and sending the correct CRC, which is calculated by SigmaStudio. If an error occurs, it can be cleared by setting the CRCEN bit low, fixing the error (presumably by reloading the program), and then setting the CRCEN bit high again.

Address	Bit 7	Bit 6	Bit 5	Bit 4	Bit 3	Bit 2	Bit 1	Bit 0
0x40C0	CRC[31:24]							
0x40C1	CRC[23:16]							
0x40C2	CRC[15:8]							
0x40C3	CRC[7:0]							
0x40C4	Reserved							CRCEN

**Table 77. Cyclic Redundancy Check Registers**

Register	Address		Bit Name	Description
	Decimal	Hex		
R43	16576	0x40C0	CRC[31:24]	CRC hash sum, Bits[31:24] (read-only register)
R44	16577	0x40C1	CRC[23:16]	CRC hash sum, Bits[23:16] (read-only register)
R45	16578	0x40C2	CRC[15:8]	CRC hash sum, Bits[15:8] (read-only register)
R46	16579	0x40C3	CRC[7:0]	CRC hash sum, Bits[7:0] (read-only register)
R47	16580	0x40C4	CRCEN	CRC enable 0 = disabled (default) 1 = enabled

# ADAU1761

## R48 to R51: GPIO Pin Control 16582 to 16585 (0x40C6 to 0x40C9)

The GPIO pin control register sets the functionality of each GPIO pin as shown in Table 78. The GPIO functions use the same pins as the serial port and must be enabled in the serial data/GPIO pin configuration register (Address 0x40F4). When the GPIO pins are set to I<sup>2</sup>C/SPI port control mode, the pins are set through writes to memory locations described in Table 32. The value of the optional internal pull-up is nominally 250 kΩ.

The output CRC error and output watchdog error settings are sticky, that is, once set, they remain set until the ADAU1761 is reset.

Address	Bit 7	Bit 6	Bit 5	Bit 4	Bit 3	Bit 2	Bit 1	Bit 0
0x40C6	Reserved				GPIO0[3:0]			
0x40C7	Reserved				GPIO1[3:0]			
0x40C8	Reserved				GPIO2[3:0]			
0x40C9	Reserved				GPIO3[3:0]			

**Table 78. GPIO Pin Functionality Bit Settings**

GPIOx[3:0] Bits	GPIO Pin Function
0000	Input without debounce (default)
0001	Input with debounce (0.3 ms)
0010	Input with debounce (0.6 ms)
0011	Input with debounce (0.9 ms)
0100	Input with debounce (5 ms)
0101	Input with debounce (10 ms)
0110	Input with debounce (20 ms)
0111	Input with debounce (40 ms)
1000	Input controlled by I <sup>2</sup> C/SPI port
1001	Output set by I <sup>2</sup> C/SPI port, with pull-up
1010	Output set by I <sup>2</sup> C/SPI port, no pull-up
1011	Output set by DSP core, with pull-up
1100	Output set by DSP core, no pull-up
1101	Reserved
1110	Output CRC error (sticky)
1111	Output watchdog error (sticky)

**Table 79. GPIO Pin Control Registers**

Register	Address		Bit Name	Description
	Decimal	Hex		
R48	16582	0x40C6	GPIO0[3:0]	GPIO 0 pin function (see Table 78)
R49	16583	0x40C7	GPIO1[3:0]	GPIO 1 pin function (see Table 78)
R50	16584	0x40C8	GPIO2[3:0]	GPIO 2 pin function (see Table 78)
R51	16585	0x40C9	GPIO3[3:0]	GPIO 3 pin function (see Table 78)



**R52 to R56: Watchdog Registers 16592 to 16596 (0x40D0 to 0x40D4)**

A program counter watchdog is used when the core does block processing (which can span several samples). The watchdog flags an error if the program counter reaches a specific 24-bit value (ranging from 0x000000 to 0xFFFFFFFF) that is set in the register map. This value consists of three consecutive 8-bit register locations. The error flag sends a high signal to one of the GPIO pins. The watchdog function must be enabled by setting the DOGEN bit high in Register R52 (Address 0x40D0).

The watchdog error bit (DOGER) is the 1-bit watchdog error flag that can be sent to a GPIO pin, as described in Table 78. This error flag can connect, for example, to an interrupt pin on a microcontroller in the system. The flag is reset when the DOGEN bit goes low. This flag can also be read back over the control port from Register R56 (Address 0x40D4).

Address	Bit 7	Bit 6	Bit 5	Bit 4	Bit 3	Bit 2	Bit 1	Bit 0
0x40D0	Reserved							DOGEN
0x40D1	DOG[23:16]							
0x40D2	DOG[15:8]							
0x40D3	DOG[7:0]							
0x40D4	Reserved							DOGER

**Table 80. Watchdog Registers**

Register	Address		Bit Name	Description			
	Decimal	Hex					
R52	16592	0x40D0	DOGEN	Watchdog enable bit. 0 = disabled (default). 1 = enabled.			
R53	16593	0x40D1	DOG[23:16]	Watchdog value, Bits[23:16] (MSB).			
R54	16594	0x40D2	DOG[15:8]	Watchdog value, Bits[15:8].			
R55	16595	0x40D3	DOG[7:0]	Watchdog value, Bits[7:0].			
				<b>DOG[23:16]</b>	<b>DOG[15:8]</b>	<b>DOG[7:0]</b>	<b>Hex Value</b>
				00000000	00000000	00000000	0x000000 (default)
				11111111	11111111	11111111	0xFFFFFFFF
R56	16596	0x40D4	DOGER	Watchdog error (read-only bit). 0 = no error (default). 1 = error.			

**R57: DSP Sampling Rate Setting 16619 (0x40EB)**

Bit 7	Bit 6	Bit 5	Bit 4	Bit 3	Bit 2	Bit 1	Bit 0
Reserved					DSPSR[2:0]		

**Table 81. DSP Sampling Rate Setting Register**

Bit	Bit Name	Description																											
[2:0]	DSPSR[2:0]	SigmaDSP core sampling rate. The DSP sampling rate is a ratio of the base sampling rate, $f_s$ . The base sampling rate is determined by the operating frequency of the core clock. For most applications, the SigmaDSP core sampling rate should equal the converter sampling rate (set using the CONVSR[2:0] bits in Register R17) and the serial port sampling rate (set using the SPSR[2:0] bits in Register R64).																											
		<table border="1"> <thead> <tr> <th>Setting</th> <th>Sampling Rate</th> <th>Base Sampling Rate (<math>f_s = 48</math> kHz)</th> </tr> </thead> <tbody> <tr> <td>000</td> <td><math>f_s/0.5</math></td> <td>96 kHz, base</td> </tr> <tr> <td>001</td> <td><math>f_s</math></td> <td>48 kHz (default)</td> </tr> <tr> <td>010</td> <td><math>f_s/1.5</math></td> <td>32 kHz</td> </tr> <tr> <td>011</td> <td><math>f_s/2</math></td> <td>24 kHz</td> </tr> <tr> <td>100</td> <td><math>f_s/3</math></td> <td>16 kHz</td> </tr> <tr> <td>101</td> <td><math>f_s/4</math></td> <td>12 kHz</td> </tr> <tr> <td>110</td> <td><math>f_s/6</math></td> <td>8 kHz</td> </tr> <tr> <td>111</td> <td>Reserved</td> <td></td> </tr> </tbody> </table>	Setting	Sampling Rate	Base Sampling Rate ( $f_s = 48$ kHz)	000	$f_s/0.5$	96 kHz, base	001	$f_s$	48 kHz (default)	010	$f_s/1.5$	32 kHz	011	$f_s/2$	24 kHz	100	$f_s/3$	16 kHz	101	$f_s/4$	12 kHz	110	$f_s/6$	8 kHz	111	Reserved	
Setting	Sampling Rate	Base Sampling Rate ( $f_s = 48$ kHz)																											
000	$f_s/0.5$	96 kHz, base																											
001	$f_s$	48 kHz (default)																											
010	$f_s/1.5$	32 kHz																											
011	$f_s/2$	24 kHz																											
100	$f_s/3$	16 kHz																											
101	$f_s/4$	12 kHz																											
110	$f_s/6$	8 kHz																											
111	Reserved																												

# ADAU1761

## R58: Serial Input Route Control 16626 (0x40F2)

Bit 7	Bit 6	Bit 5	Bit 4	Bit 3	Bit 2	Bit 1	Bit 0
Reserved				SINRT[3:0]			

Table 82. Serial Input Route Control Register

Bit	Bit Name	Description																																		
[3:0]	SINRT[3:0]	Serial data input routing. This register sets the input where the DACs receive serial data. This location can be from the DSP or from any TDM slot on the serial port.																																		
		<table border="1"> <thead> <tr> <th>Setting</th> <th>Routing</th> </tr> </thead> <tbody> <tr><td>0000</td><td>DSP to DACs [L, R] (default)</td></tr> <tr><td>0001</td><td>Serial input [L0, R0] to DACs [L, R]</td></tr> <tr><td>0010</td><td>Reserved</td></tr> <tr><td>0011</td><td>Serial input [L1, R1] to DACs [L, R]</td></tr> <tr><td>0100</td><td>Reserved</td></tr> <tr><td>0101</td><td>Serial input [L2, R2] to DACs [L, R]</td></tr> <tr><td>0110</td><td>Reserved</td></tr> <tr><td>0111</td><td>Serial input [L3, R3] to DACs [L, R]</td></tr> <tr><td>1000</td><td>Reserved</td></tr> <tr><td>1001</td><td>Serial input [R0, L0] to DACs [L, R]</td></tr> <tr><td>1010</td><td>Reserved</td></tr> <tr><td>1011</td><td>Serial input [R1, L1] to DACs [L, R]</td></tr> <tr><td>1100</td><td>Reserved</td></tr> <tr><td>1101</td><td>Serial input [R2, L2] to DACs [L, R]</td></tr> <tr><td>1110</td><td>Reserved</td></tr> <tr><td>1111</td><td>Serial input [R3, L3] to DACs [L, R]</td></tr> </tbody> </table>	Setting	Routing	0000	DSP to DACs [L, R] (default)	0001	Serial input [L0, R0] to DACs [L, R]	0010	Reserved	0011	Serial input [L1, R1] to DACs [L, R]	0100	Reserved	0101	Serial input [L2, R2] to DACs [L, R]	0110	Reserved	0111	Serial input [L3, R3] to DACs [L, R]	1000	Reserved	1001	Serial input [R0, L0] to DACs [L, R]	1010	Reserved	1011	Serial input [R1, L1] to DACs [L, R]	1100	Reserved	1101	Serial input [R2, L2] to DACs [L, R]	1110	Reserved	1111	Serial input [R3, L3] to DACs [L, R]
Setting	Routing																																			
0000	DSP to DACs [L, R] (default)																																			
0001	Serial input [L0, R0] to DACs [L, R]																																			
0010	Reserved																																			
0011	Serial input [L1, R1] to DACs [L, R]																																			
0100	Reserved																																			
0101	Serial input [L2, R2] to DACs [L, R]																																			
0110	Reserved																																			
0111	Serial input [L3, R3] to DACs [L, R]																																			
1000	Reserved																																			
1001	Serial input [R0, L0] to DACs [L, R]																																			
1010	Reserved																																			
1011	Serial input [R1, L1] to DACs [L, R]																																			
1100	Reserved																																			
1101	Serial input [R2, L2] to DACs [L, R]																																			
1110	Reserved																																			
1111	Serial input [R3, L3] to DACs [L, R]																																			

## R59: Serial Output Route Control 16627 (0x40F3)

Bit 7	Bit 6	Bit 5	Bit 4	Bit 3	Bit 2	Bit 1	Bit 0
Reserved				SOUTRT[3:0]			

Table 83. Serial Output Route Control Register

Bit	Bit Name	Description																																		
[3:0]	SOUTRT[3:0]	Serial data output routing. This register sets the serial data route output from the ADCs. This location can be to the DSP or to any TDM slot on the serial port.																																		
		<table border="1"> <thead> <tr> <th>Setting</th> <th>Routing</th> </tr> </thead> <tbody> <tr><td>0000</td><td>ADCs [L, R] to DSP (default)</td></tr> <tr><td>0001</td><td>ADCs [L, R] to serial output [L0, R0]</td></tr> <tr><td>0010</td><td>Reserved</td></tr> <tr><td>0011</td><td>ADCs [L, R] to serial output [L1, R1]</td></tr> <tr><td>0100</td><td>Reserved</td></tr> <tr><td>0101</td><td>ADCs [L, R] to serial output [L2, R2]</td></tr> <tr><td>0110</td><td>Reserved</td></tr> <tr><td>0111</td><td>ADCs [L, R] to serial output [L3, R3]</td></tr> <tr><td>1000</td><td>Reserved</td></tr> <tr><td>1001</td><td>ADCs [L, R] to serial output [R0, L0]</td></tr> <tr><td>1010</td><td>Reserved</td></tr> <tr><td>1011</td><td>ADCs [L, R] to serial output [R1, L1]</td></tr> <tr><td>1100</td><td>Reserved</td></tr> <tr><td>1101</td><td>ADCs [L, R] to serial output [R2, L2]</td></tr> <tr><td>1110</td><td>Reserved</td></tr> <tr><td>1111</td><td>ADCs [L, R] to serial output [R3, L3]</td></tr> </tbody> </table>	Setting	Routing	0000	ADCs [L, R] to DSP (default)	0001	ADCs [L, R] to serial output [L0, R0]	0010	Reserved	0011	ADCs [L, R] to serial output [L1, R1]	0100	Reserved	0101	ADCs [L, R] to serial output [L2, R2]	0110	Reserved	0111	ADCs [L, R] to serial output [L3, R3]	1000	Reserved	1001	ADCs [L, R] to serial output [R0, L0]	1010	Reserved	1011	ADCs [L, R] to serial output [R1, L1]	1100	Reserved	1101	ADCs [L, R] to serial output [R2, L2]	1110	Reserved	1111	ADCs [L, R] to serial output [R3, L3]
Setting	Routing																																			
0000	ADCs [L, R] to DSP (default)																																			
0001	ADCs [L, R] to serial output [L0, R0]																																			
0010	Reserved																																			
0011	ADCs [L, R] to serial output [L1, R1]																																			
0100	Reserved																																			
0101	ADCs [L, R] to serial output [L2, R2]																																			
0110	Reserved																																			
0111	ADCs [L, R] to serial output [L3, R3]																																			
1000	Reserved																																			
1001	ADCs [L, R] to serial output [R0, L0]																																			
1010	Reserved																																			
1011	ADCs [L, R] to serial output [R1, L1]																																			
1100	Reserved																																			
1101	ADCs [L, R] to serial output [R2, L2]																																			
1110	Reserved																																			
1111	ADCs [L, R] to serial output [R3, L3]																																			

**R60: Serial Data/GPIO Pin Configuration 16628 (0x40F4)**

The serial data/GPIO pin configuration register controls the functionality of the serial data port pins. If the bits in this register are set to 1, these pins are configured as GPIO interfaces to the SigmaDSP. If these bits are set to 0, they are configured as serial data I/O port pins.

Bit 7	Bit 6	Bit 5	Bit 4	Bit 3	Bit 2	Bit 1	Bit 0
Reserved				LRGP3	BGP2	SDOGP1	SDIGP0

**Table 84. Serial Data/GPIO Pin Configuration Register**

Bit	Bit Name	Description
3	LRGP3	LRCLK or GPIO3 pin configuration select. 0 = LRCLK enabled (default). 1 = GPIO3 enabled.
2	BGP2	BCLK or GPIO2 pin configuration select. 0 = BCLK enabled (default). 1 = GPIO2 enabled.
1	SDOGP1	ADC_SDATA or GPIO1 pin configuration select. 0 = ADC_SDATA enabled (default). 1 = GPIO1 enabled.
0	SDIGP0	DAC_SDATA or GPIO0 pin configuration select. 0 = DAC_SDATA enabled (default). 1 = GPIO0 enabled.

**R61: DSP Enable 16629 (0x40F5)**

Bit 7	Bit 6	Bit 5	Bit 4	Bit 3	Bit 2	Bit 1	Bit 0
Reserved							DSPEN

**Table 85. DSP Enable Register**

Bit	Bit Name	Description
0	DSPEN	Enables the DSP. Set this bit before setting the DSPRUN bit in Register R62 (Address 0x40F6). 0 = DSP disabled (default). 1 = DSP enabled.

**R62: DSP Run 16630 (0x40F6)**

Bit 7	Bit 6	Bit 5	Bit 4	Bit 3	Bit 2	Bit 1	Bit 0
Reserved							DSPRUN

**Table 86. DSP Run Register**

Bit	Bit Name	Description
0	DSPRUN	Run the DSP. Set the DSPEN bit in Register R61 (Address 0x40F5) before setting this bit. 0 = DSP off (default). 1 = run the DSP.

# ADAU1761

## R63: DSP Slew Modes 16631 (0x40F7)

The DSP slew modes register sets the slew source for each output. The slew source can be either the DSP (digital slew) or the codec (analog slew). Setting these bits to Logic 0 enables the codec to provide volume slew according to the ASLEW[1:0] bits in Register R34 (playback pop/click suppression register, Address 0x4028). When these bits are set to Logic 1, the slew is provided and defined by the DSP program, disabling the codec volume slew.

Bit 7	Bit 6	Bit 5	Bit 4	Bit 3	Bit 2	Bit 1	Bit 0
Reserved			MOSLW	ROSLW	LOSLW	RHPSLW	LHPSLW

Table 87. DSP Slew Modes Register

Bit	Bit Name	Description
4	MOSLW	Mono output slew generation. 0 = codec (default). 1 = DSP.
3	ROSLW	Line output right slew generation. 0 = codec (default). 1 = DSP.
2	LOSLW	Line output left slew generation. 0 = codec (default). 1 = DSP.
1	RHPSLW	Headphone right slew generation. 0 = codec (default). 1 = DSP.
0	LHPSLW	Headphone left slew generation. 0 = codec (default). 1 = DSP.

## R64: Serial Port Sampling Rate 16632 (0x40F8)

Bit 7	Bit 6	Bit 5	Bit 4	Bit 3	Bit 2	Bit 1	Bit 0
Reserved					SPSR[2:0]		

Table 88. Serial Port Sampling Rate Register

Bit	Bit Name	Description																											
[2:0]	SPSR[2:0]	Serial port sampling rate. The serial port sampling rate is a ratio of the base sampling rate, $f_s$ . The base sampling rate is determined by the operating frequency of the core clock. For most applications, the serial port sampling rate should equal the converter sampling rate (set using the CONVSR[2:0] bits in Register R17) and the DSP sampling rate (set using the DSPSR[2:0] bits in Register R57).																											
		<table border="1"> <thead> <tr> <th>Setting</th> <th>Sampling Rate</th> <th>Base Sampling Rate (<math>f_s = 48</math> kHz)</th> </tr> </thead> <tbody> <tr> <td>000</td> <td><math>f_s</math></td> <td>48 kHz, base (default)</td> </tr> <tr> <td>001</td> <td><math>f_s/6</math></td> <td>8 kHz</td> </tr> <tr> <td>010</td> <td><math>f_s/4</math></td> <td>12 kHz</td> </tr> <tr> <td>011</td> <td><math>f_s/3</math></td> <td>16 kHz</td> </tr> <tr> <td>100</td> <td><math>f_s/2</math></td> <td>24 kHz</td> </tr> <tr> <td>101</td> <td><math>f_s/1.5</math></td> <td>32 kHz</td> </tr> <tr> <td>110</td> <td><math>f_s/0.5</math></td> <td>96 kHz</td> </tr> <tr> <td>111</td> <td>Reserved</td> <td></td> </tr> </tbody> </table>	Setting	Sampling Rate	Base Sampling Rate ( $f_s = 48$ kHz)	000	$f_s$	48 kHz, base (default)	001	$f_s/6$	8 kHz	010	$f_s/4$	12 kHz	011	$f_s/3$	16 kHz	100	$f_s/2$	24 kHz	101	$f_s/1.5$	32 kHz	110	$f_s/0.5$	96 kHz	111	Reserved	
Setting	Sampling Rate	Base Sampling Rate ( $f_s = 48$ kHz)																											
000	$f_s$	48 kHz, base (default)																											
001	$f_s/6$	8 kHz																											
010	$f_s/4$	12 kHz																											
011	$f_s/3$	16 kHz																											
100	$f_s/2$	24 kHz																											
101	$f_s/1.5$	32 kHz																											
110	$f_s/0.5$	96 kHz																											
111	Reserved																												

**R65: Clock Enable 0 16633 (0x40F9)**

This register disables or enables the digital clock engine for different blocks within the ADAU1761. For maximum power saving, use this register to disable blocks that are not being used.

Bit 7	Bit 6	Bit 5	Bit 4	Bit 3	Bit 2	Bit 1	Bit 0
Reserved	SLEWPD	ALCPD	DECPD	SOUTPD	INTPD	SINPD	SPPD

**Table 89. Clock Enable 0 Register**

Bit	Bit Name	Description
6	SLEWPD	Codec slew digital clock engine enable. When powered down, the analog playback path volume controls are disabled and stay set to their current state. 0 = powered down (default). 1 = enabled.
5	ALCPD	ALC digital clock engine enable. 0 = powered down (default). 1 = enabled.
4	DECPD	Decimator resync (dejitter) digital clock engine enable. 0 = powered down (default). 1 = enabled.
3	SOUTPD	Serial routing outputs digital clock engine enable. 0 = powered down (default). 1 = enabled.
2	INTPD	Interpolator resync (dejitter) digital clock engine enable. 0 = powered down (default). 1 = enabled.
1	SINPD	Serial routing inputs digital clock engine enable. 0 = powered down (default). 1 = enabled.
0	SPPD	Serial port digital clock engine enable. 0 = powered down (default). 1 = enabled.

**R66: Clock Enable 1 16634 (0x40FA)**

This register enables Digital Clock Generator 0 and Digital Clock Generator 1. Digital Clock Generator 0 generates sample rates for the ADCs, DACs, and DSP. Digital Clock Generator 1 generates BCLK and LRCLK for the serial port when the part is in master mode. For maximum power saving, use this register to disable clocks that are not being used.

Bit 7	Bit 6	Bit 5	Bit 4	Bit 3	Bit 2	Bit 1	Bit 0
Reserved						CLK0	CLK1

**Table 90. Clock Enable 1 Register**

Bit	Bit Name	Description
1	CLK0	Digital Clock Generator 0. 0 = off (default). 1 = on.
0	CLK1	Digital Clock Generator 1. 0 = off (default). 1 = on.

# ADAU1761

**Table 91. R8 and R9 Volume Settings**

Binary Value	Volume Setting (dB)
000000	-12
000001	-11.25
000010	-10.5
000011	-9.75
000100	-9
000101	-8.25
000110	-7.5
000111	-6.75
001000	-6
001001	-5.25
001010	-4.5
001011	-3.75
001100	-3
001101	-2.25
001110	-1.5
001111	-0.75
010000	0
010001	0.75
010010	1.5
010011	2.25
010100	3
010101	3.75
010110	4.5
010111	5.25
011000	6
011001	6.75
011010	7.5
011011	8.25
011100	9
011101	9.75
011110	10.5
011111	11.25
100000	12
100001	12.75
100010	13.5
100011	14.25
100100	15
100101	15.75
100110	16.5
100111	17.25
101000	18
101001	18.75
101010	19.5
101011	20.25
101100	21
101101	21.75
101110	22.5
101111	23.25
110000	24
110001	24.75
110010	25.5

Binary Value	Volume Setting (dB)
110011	26.25
110100	27
110101	27.75
110110	28.5
110111	29.25
111000	30
111001	30.75
111010	31.5
111011	32.25
111100	33
111101	33.75
111110	34.5
111111	35.25

**Table 92. R14 Noise Gate Threshold**

Binary Value	Noise Gate Threshold (dB)
00000	-76.5
00001	-75
00010	-73.5
00011	-72
00100	-70.5
00101	-69
00110	-67.5
00111	-66
01000	-64.5
01001	-63
01010	-61.5
01011	-60
01100	-58.5
01101	-57
01110	-55.5
01111	-54
10000	-52.5
10001	-51
10010	-49.5
10011	-48
10100	-46.5
10101	-45
10110	-43.5
10111	-42
11000	-40.5
11001	-39
11010	-37.5
11011	-36
11100	-34.5
11101	-33
11110	-31.5
11111	-30

Table 93. R20, R21, R37, and R38 Volume Settings

Binary Value	Volume Attenuation (dB)	Binary Value	Volume Attenuation (dB)
00000000	0	00110000	-18
00000001	-0.375	00110001	-18.375
00000010	-0.75	00110010	-18.75
00000011	-1.125	00110011	-19.125
00000100	-1.5	00110100	-19.5
00000101	-1.875	00110101	-19.875
00000110	-2.25	00110110	-20.25
00000111	-2.625	00110111	-20.625
00001000	-3	00111000	-21
00001001	-3.375	00111001	-21.375
00001010	-3.75	00111010	-21.75
00001011	-4.125	00111011	-22.125
00001100	-4.5	00111100	-22.5
00001101	-4.875	00111101	-22.875
00001110	-5.25	00111110	-23.25
00001111	-5.625	00111111	-23.625
00010000	-6	01000000	-24
00010001	-6.375	01000001	-24.375
00010010	-6.75	01000010	-24.75
00010011	-7.125	01000011	-25.125
00010100	-7.5	01000100	-25.5
00010101	-7.875	01000101	-25.875
00010110	-8.25	01000110	-26.25
00010111	-8.625	01000111	-26.625
00011000	-9	01001000	-27
00011001	-9.375	01001001	-27.375
00011010	-9.75	01001010	-27.75
00011011	-10.125	01001011	-28.125
00011100	-10.5	01001100	-28.5
00011101	-10.875	01001101	-28.875
00011110	-11.25	01001110	-29.25
00011111	-11.625	01001111	-29.625
00100000	-12	01010000	-30
00100001	-12.375	01010001	-30.375
00100010	-12.75	01010010	-30.75
00100011	-13.125	01010011	-31.125
00100100	-13.5	01010100	-31.5
00100101	-13.875	01010101	-31.875
00100110	-14.25	01010110	-32.25
00100111	-14.625	01010111	-32.625
00101000	-15	01011000	-33
00101001	-15.375	01011001	-33.375
00101010	-15.75	01011010	-33.75
00101011	-16.125	01011011	-34.125
00101100	-16.5	01011100	-34.5
00101101	-16.875	01011101	-34.875
00101110	-17.25	01011110	-35.25
00101111	-17.625	01011111	-35.625

# ADAU1761

Binary Value	Volume Attenuation (dB)	Binary Value	Volume Attenuation (dB)
01100000	-36	10010001	-54.375
01100001	-36.375	10010010	-54.75
01100010	-36.75	10010011	-55.125
01100011	-37.125	10010100	-55.5
01100100	-37.5	10010101	-55.875
01100101	-37.875	10010110	-56.25
01100110	-38.25	10010111	-56.625
01100111	-38.625	10011000	-57
01101000	-39	10011001	-57.375
01101001	-39.375	10011010	-57.75
01101010	-39.75	10011011	-58.125
01101011	-40.125	10011100	-58.5
01101100	-40.5	10011101	-58.875
01101101	-40.875	10011110	-59.25
01101110	-41.25	10011111	-59.625
01101111	-41.625	10100000	-60
01110000	-42	10100001	-60.375
01110001	-42.375	10100010	-60.75
01110010	-42.75	10100011	-61.125
01110011	-43.125	10100100	-61.5
01110100	-43.5	10100101	-61.875
01110101	-43.875	10100110	-62.25
01110110	-44.25	10100111	-62.625
01110111	-44.625	10101000	-63
01111000	-45	10101001	-63.375
01111001	-45.375	10101010	-63.75
01111010	-45.75	10101011	-64.125
01111011	-46.125	10101100	-64.5
01111100	-46.5	10101101	-64.875
01111101	-46.875	10101110	-65.25
01111110	-47.25	10101111	-65.625
01111111	-47.625	10110000	-66
10000000	-48	10110001	-66.375
10000001	-48.375	10110010	-66.75
10000010	-48.75	10110011	-67.125
10000011	-49.125	10110100	-67.5
10000100	-49.5	10110101	-67.875
10000101	-49.875	10110110	-68.25
10000110	-50.25	10110111	-68.625
10000111	-50.625	10111000	-69
10001000	-51	10111001	-69.375
10001001	-51.375	10111010	-69.75
10001010	-51.75	10111011	-70.125
10001011	-52.125	10111100	-70.5
10001100	-52.5	10111101	-70.875
10001101	-52.875	10111110	-71.25
10001110	-53.25	10111111	-71.625
10001111	-53.625	11000000	-72
10010000	-54	11000001	-72.375



Binary Value	Volume Attenuation (dB)
11000010	-72.75
11000011	-73.125
11000100	-73.5
11000101	-73.875
11000110	-74.25
11000111	-74.625
11001000	-75
11001001	-75.375
11001010	-75.75
11001011	-76.125
11001100	-76.5
11001101	-76.875
11001110	-77.25
11001111	-77.625
11010000	-78
11010001	-78.375
11010010	-78.75
11010011	-79.125
11010100	-79.5
11010101	-79.875
11010110	-80.25
11010111	-80.625
11011000	-81
11011001	-81.375
11011010	-81.75
11011011	-82.125
11011100	-82.5
11011101	-82.875
11011110	-83.25
11011111	-83.625
11100000	-84
11100001	-84.375
11100010	-84.75
11100011	-85.125
11100100	-85.5
11100101	-85.875
11100110	-86.25
11100111	-86.625
11101000	-87
11101001	-87.375
11101010	-87.75
11101011	-88.125
11101100	-88.5
11101101	-88.875
11101110	-89.25
11101111	-89.625
11110000	-90
11110001	-90.375
11110010	-90.75

Binary Value	Volume Attenuation (dB)
11110011	-91.125
11110100	-91.5
11110101	-91.875
11110110	-92.25
11110111	-92.625
11111000	-93
11111001	-93.375
11111010	-93.75
11111011	-94.125
11111100	-94.5
11111101	-94.875
11111110	-95.25
11111111	-95.625

Table 94. R29 through R33 Volume Settings

Binary Value	Volume Setting (dB)
000000	-57
000001	-56
000010	-55
000011	-54
000100	-53
000101	-52
000110	-51
000111	-50
001000	-49
001001	-48
001010	-47
001011	-46
001100	-45
001101	-44
001110	-43
001111	-42
010000	-41
010001	-40
010010	-39
010011	-38
010100	-37
010101	-36
010110	-35
010111	-34
011000	-33
011001	-32
011010	-31
011011	-30
011100	-29
011101	-28
011110	-27
011111	-26
100000	-25

# ADAU1761

Binary Value	Volume Setting (dB)
100001	-24
100010	-23
100011	-22
100100	-21
100101	-20
100110	-19
100111	-18
101000	-17
101001	-16
101010	-15
101011	-14
101100	-13
101101	-12
101110	-11
101111	-10
110000	-9
110001	-8
110010	-7
110011	-6
110100	-5
110101	-4
110110	-3
110111	-2
111000	-1
111001	0
111010	1
111011	2
111100	3
111101	4
111110	5
111111	6

# OUTLINE DIMENSIONS

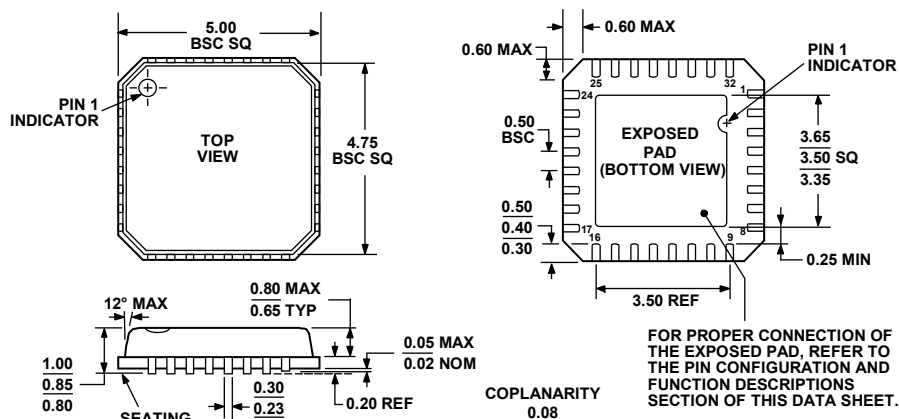

COMPLIANT TO JEDEC STANDARDS MO-220-VHHD-2

Figure 69. 32-Lead Lead Frame Chip Scale Package [LFCSP\_VQ]  
 5 mm × 5 mm Body, Very Thin Quad  
 (CP-32-4)  
 Dimensions shown in millimeters

100808-A

## ORDERING GUIDE

Model	Temperature Range	Package Description	Package Option
ADAU1761BCPZ <sup>1</sup>	-40°C to +85°C	32-Lead Lead Frame Chip Scale Package [LFCSP_VQ]	CP-32-4
ADAU1761BCPZ-R7 <sup>1</sup>	-40°C to +85°C	32-Lead Lead Frame Chip Scale Package [LFCSP_VQ], 7" Tape and Reel	CP-32-4
ADAU1761BCPZ-RL <sup>1</sup>	-40°C to +85°C	32-Lead Lead Frame Chip Scale Package [LFCSP_VQ], 13" Tape and Reel	CP-32-4
EVAL-ADAU1761Z <sup>1</sup>		Evaluation Board	

<sup>1</sup> Z = RoHS Compliant Part.

**ADAU1761**

**NOTES**